

DIE GOTIK

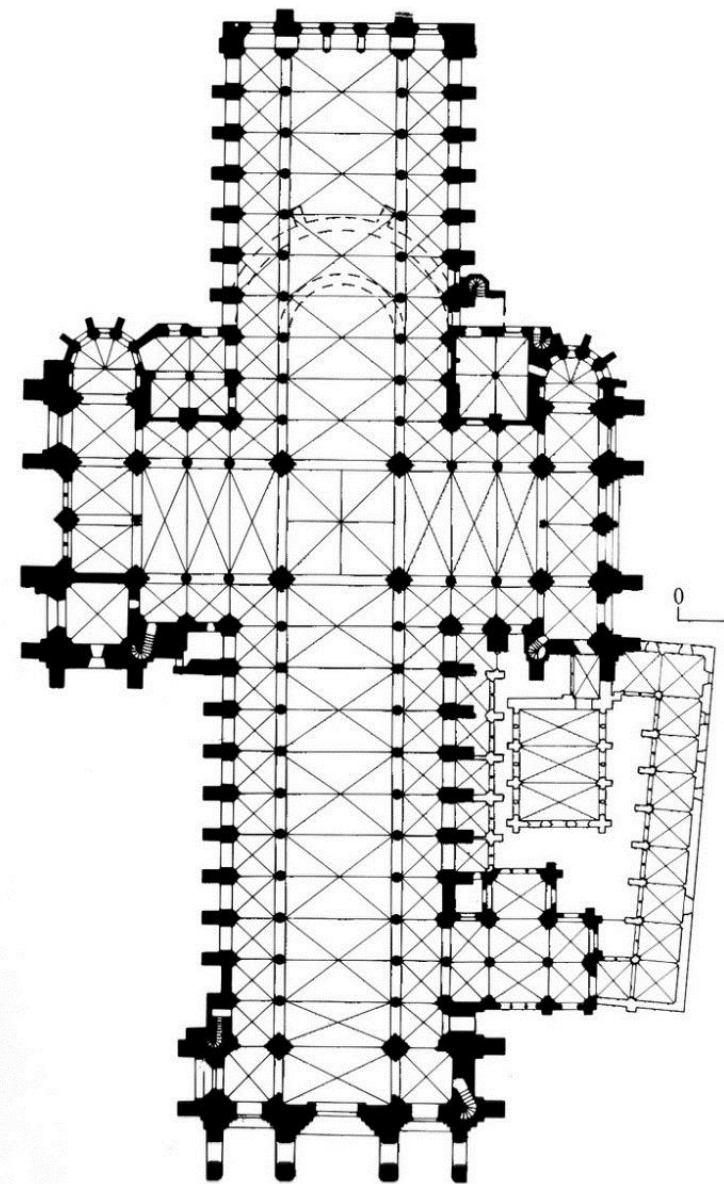

3. Sitzung ---- 10.03.2020

Die grossen Kathedralen in
Frankreich



Kathedrale von Laon
Baubeginn um 1160, Hauptaktivität um 1180-1200.
Weiterbau bis 1. Hälfte 13.Jh.

Drei Fassaden mit Türmen geplant
Querhaus mit Seitenschiffen: Betonung geometrischer
Konstruktion

Doppelturmfassade | *façade à double tour*

Wimperge und Fialen |
gables et pinacles

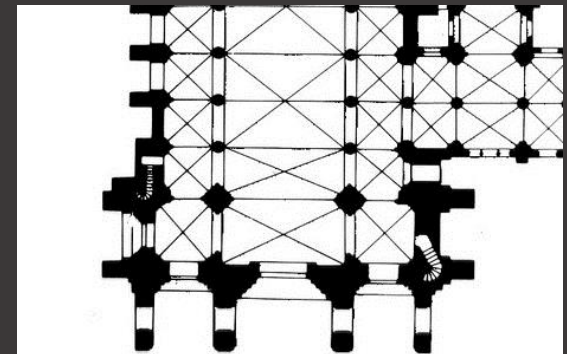
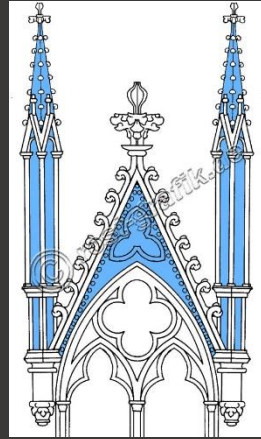



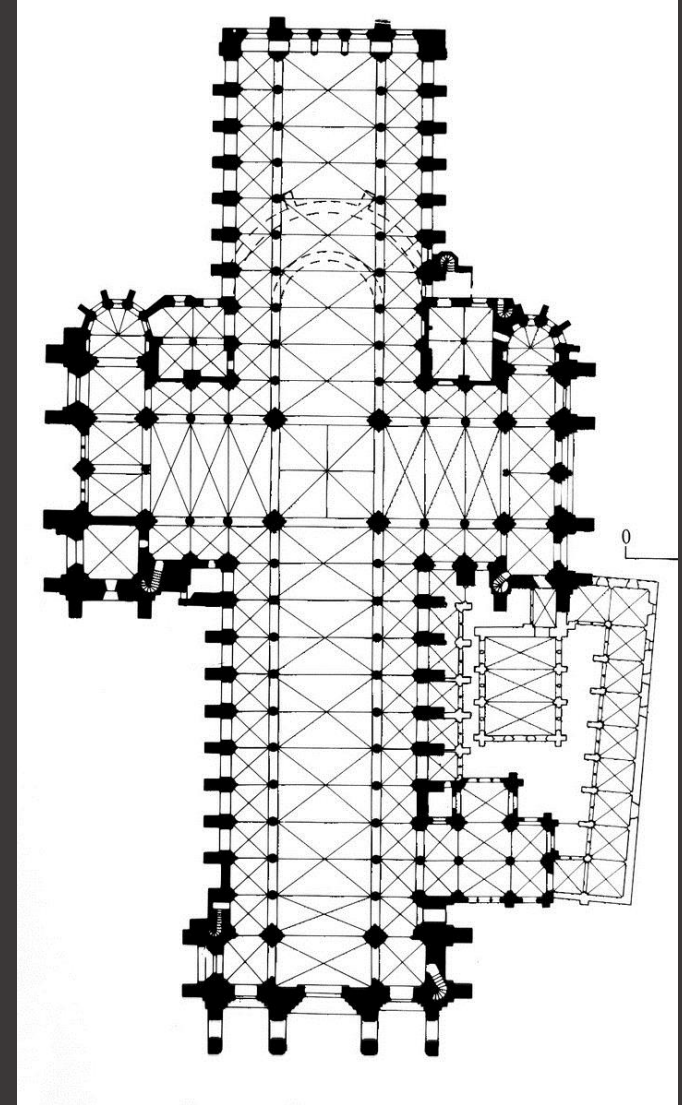

Von Noyon inspiriert, noch logischer
und konsequenter durchgegliedert

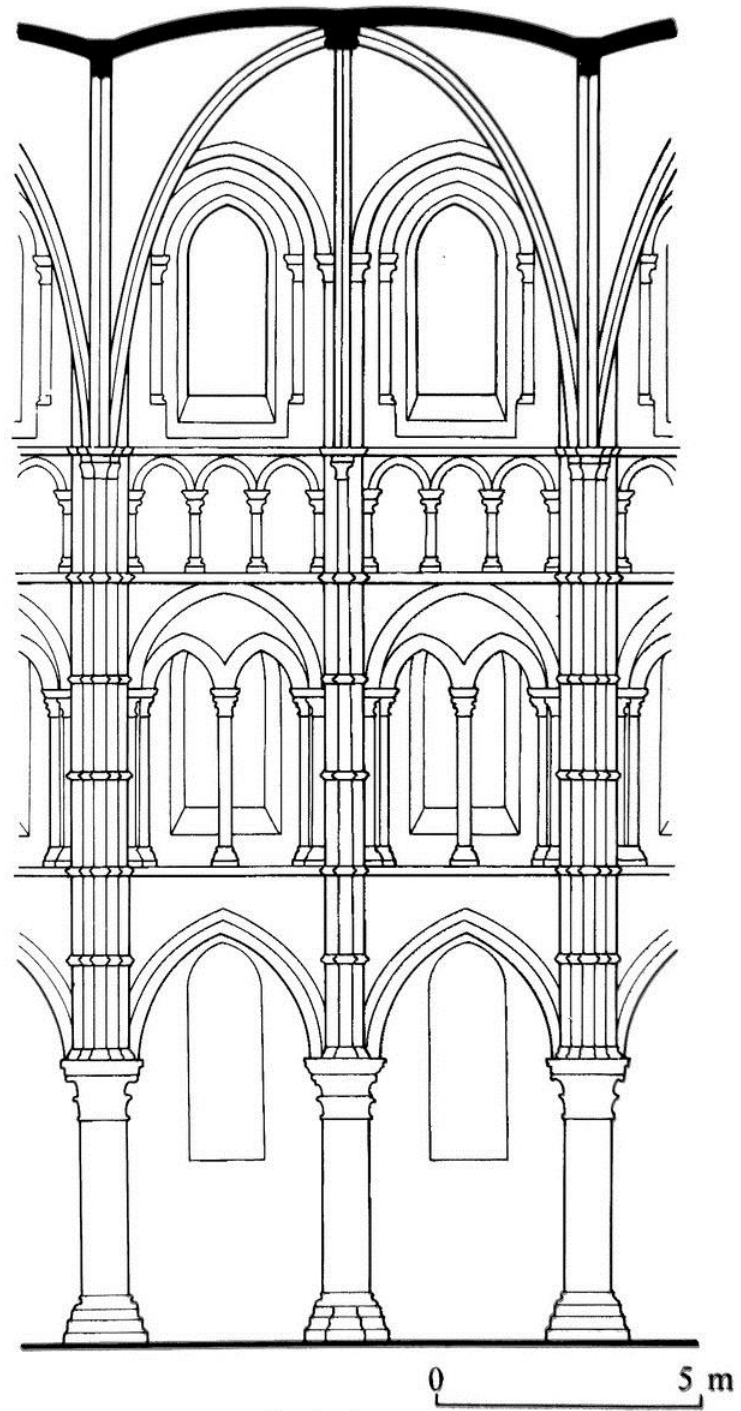



Laon



Noyon

NOTRE DAME DE LAON

COVPE LONGITVDINALE

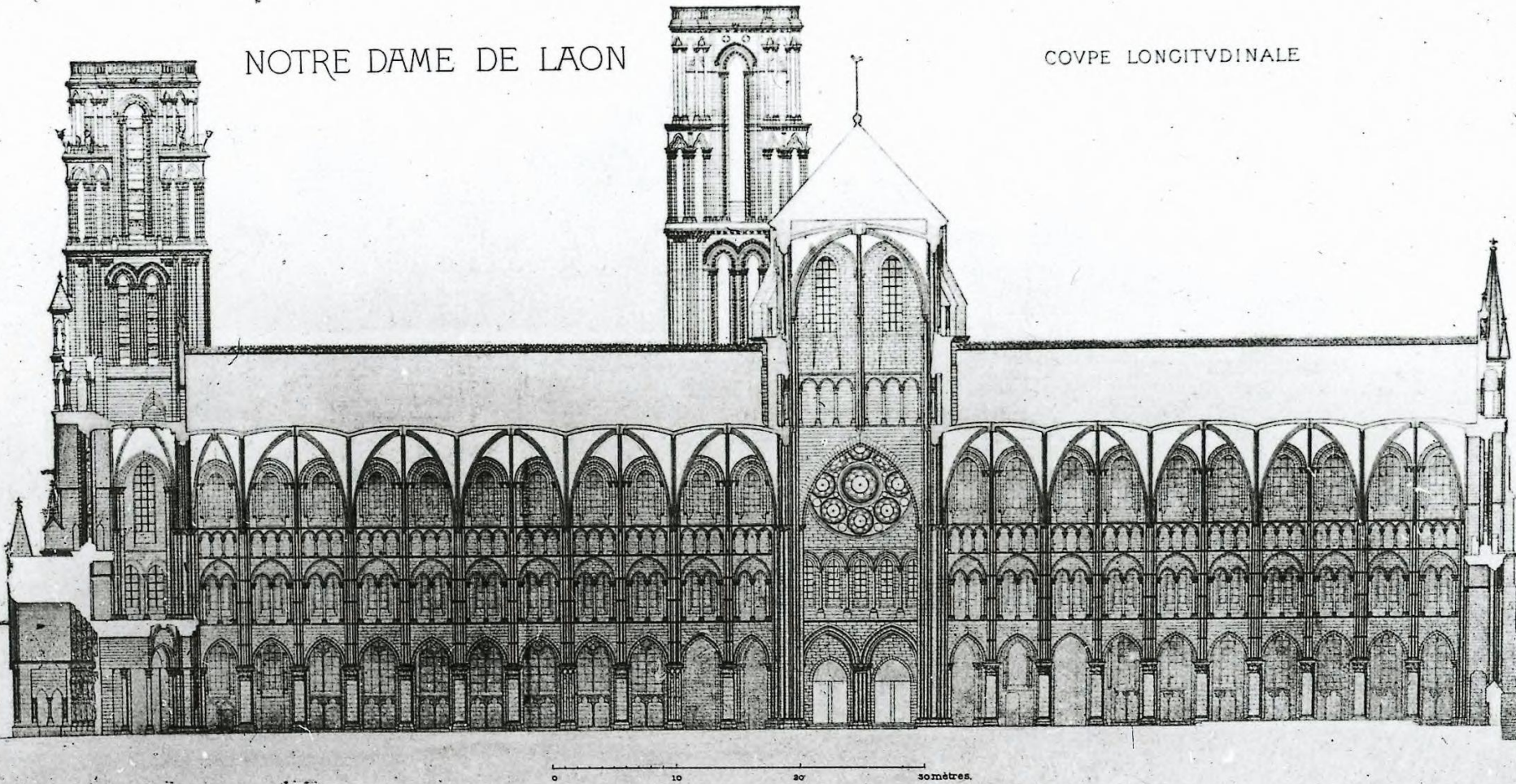

Chor nach 1200 neu errichtet, Streben nach völliger Einheitlichkeit

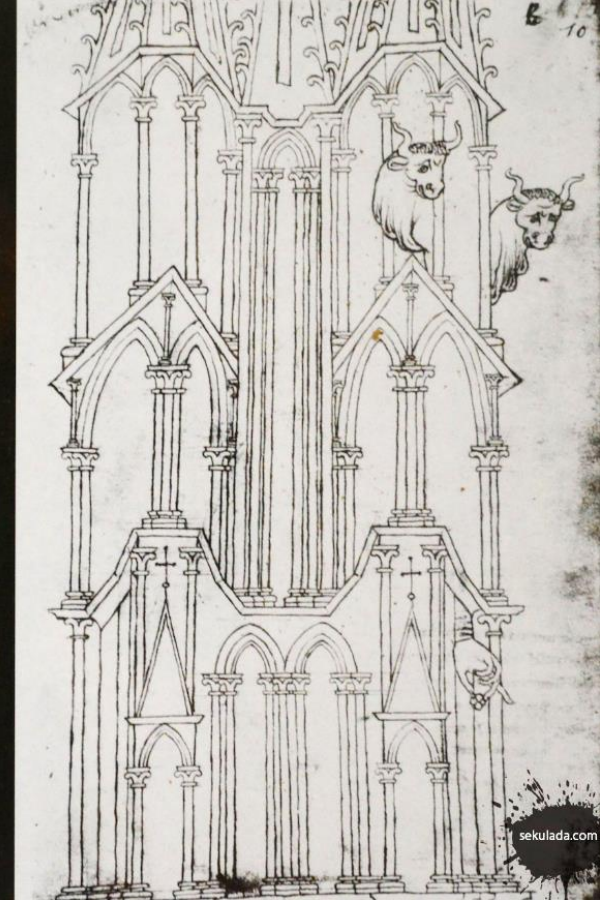
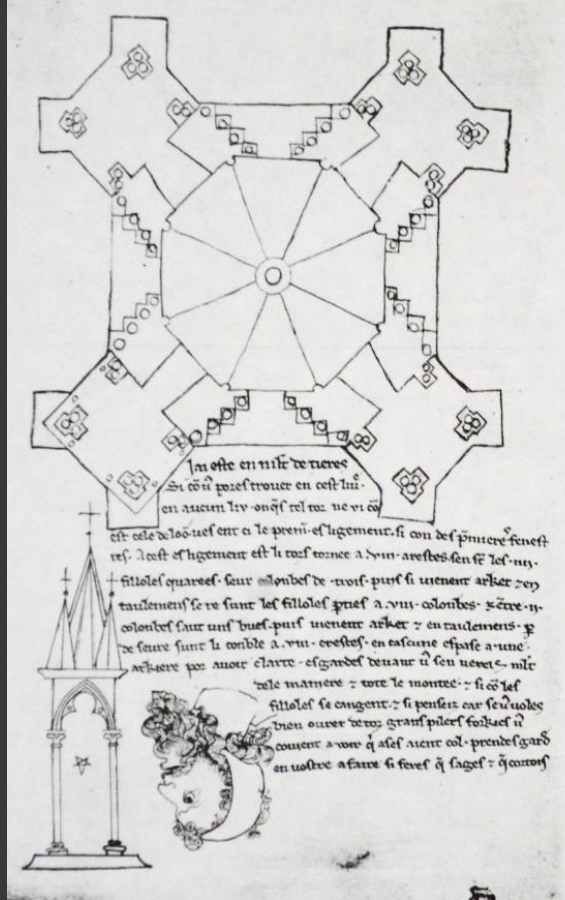

Skizzenbuch des Villard de Honnecourt (um 1230)

Entstanden auf Reisen zu Kathedralbaustellen in ganz Europa

„J'ai este en m[u]lt de tieres“

Wichtig: Zeichnungen von tatsächlichen zeitgenössischen Kathedralen

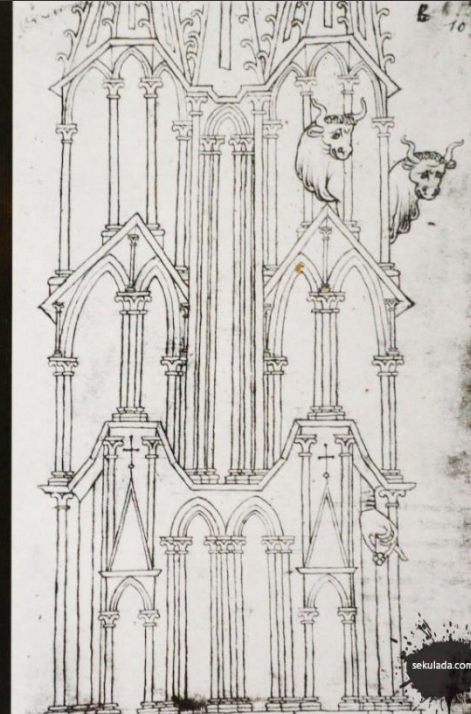
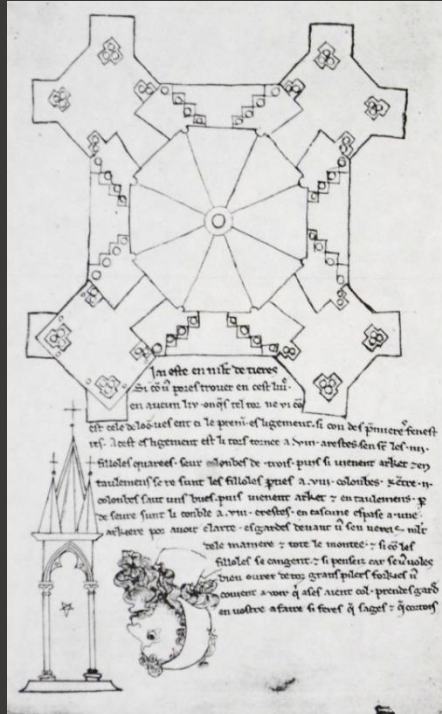

Transcription

Jai este en m[u]lt de tieres / Si com vos pores trover en cest liv[r]e.
 / en aucun liu. onques tel tor ne vi com / est cele de loon. ves ent ci
 le premier esligement.¹ si con des premieres fenest / res. a cest
 esligement est li tors tornee a .viii. arestes. sen sunt les .iiii. /
 filloles quarees. seur colonbes² de trois. puis si viennent arket et en /
 taulemens se resunt les filloles parties a .viii. colonbes. et entre .ii. /
 colonbes saut uns bues. puis viennent arket et entaulemens. par /
 deseure sunt li conble a .viii. crestes. en cascune espase a .une. /
 arkiere por avoir clarte. esgardes devant vos sen vereis m[u]lt / de
 le maniere et tote le montee. et si com les / filloles se cangent.³ et si
 penseiz car se vos voles / bien ovrer de toz⁴ grans pilers forkies vos
 covient avoir qui ases aient col. prendes garde / en vostre affaire si
 feres que sages et que cortois

Free translation

I have been in many lands, as you can discover in this book. In no place did I ever see a tower such as that at Laon. Here is its first level, with the first windows. At this level the tower is octagonal and the four turrets are square, with triple columns. Then come small arches and entablatures and more turrets formed by eight columns. Between each two columns an ox protrudes. Next come arches and entablatures, above which comes a roof with eight crests. In each space there is an arched opening to admit light. Look here and you will see how its entire elevation looks, and how the turrets are at angles. Pay attention: if you wish to build strong pier-buttresses, they must have enough depth. Take care in your work, and you will act wisely and nobly.

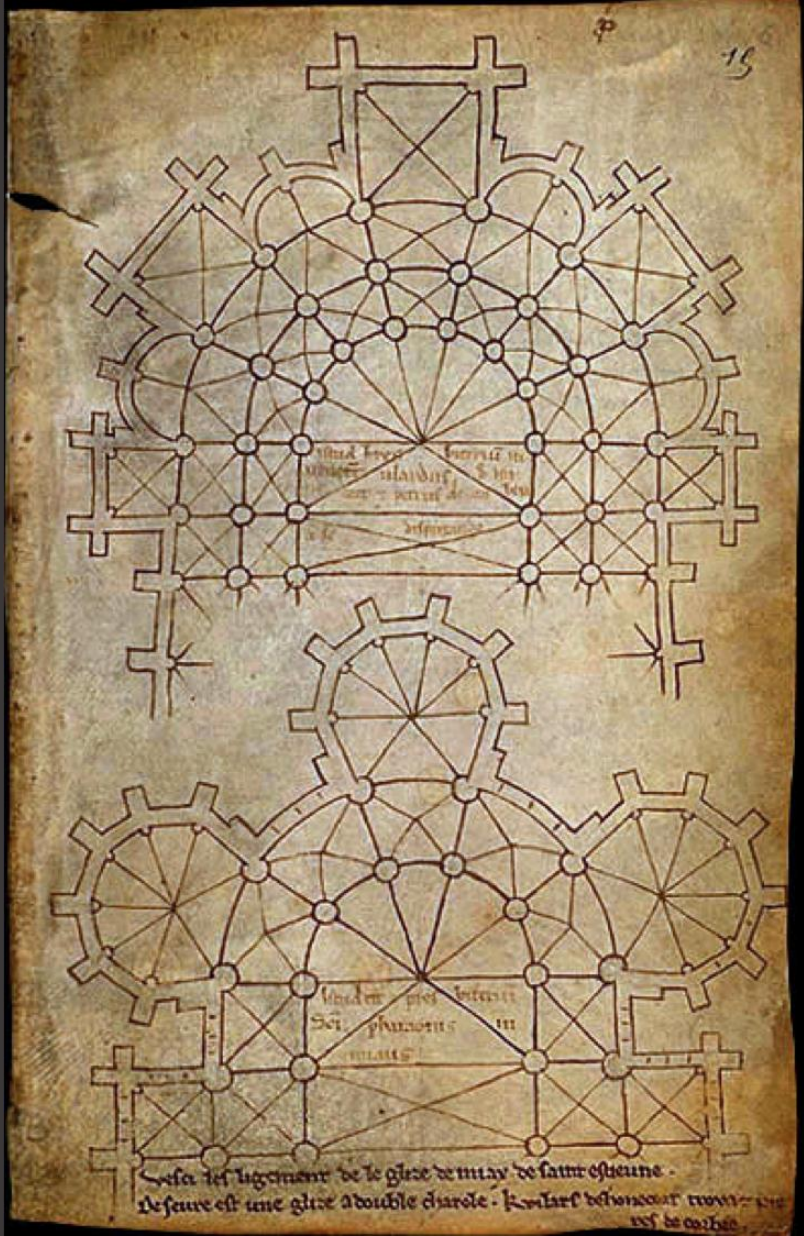
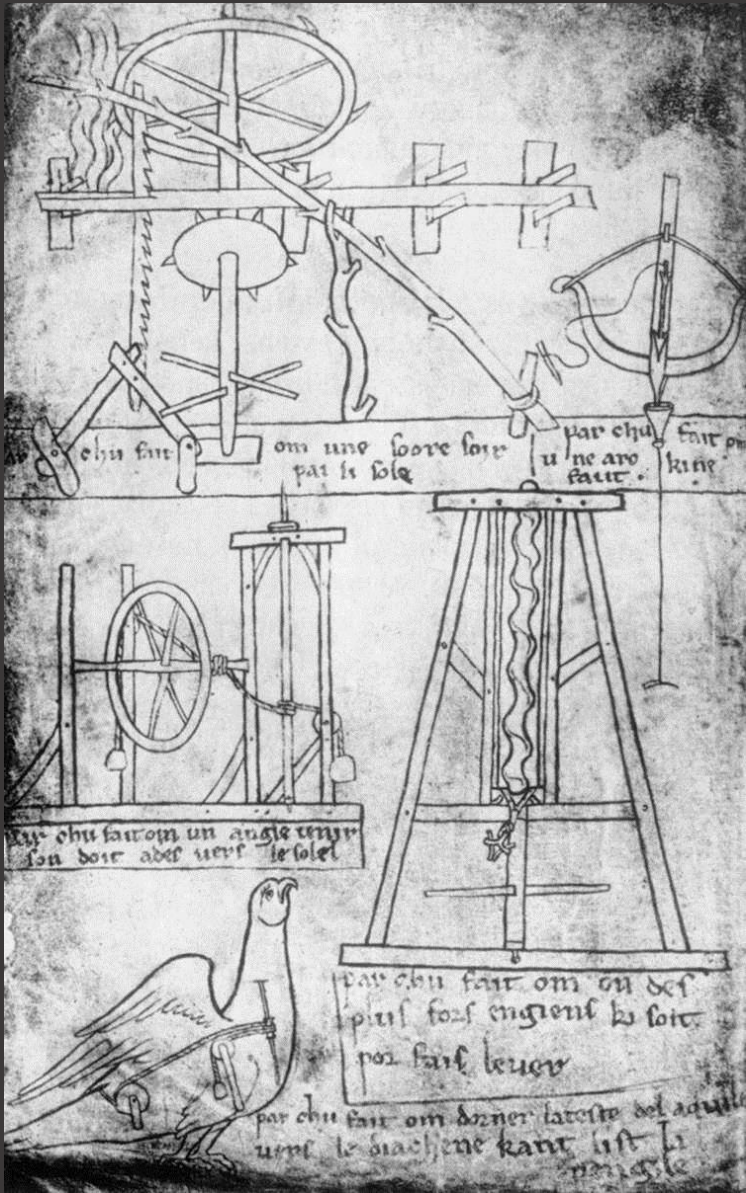

Enthält Zeichnungen von Ingenieursapparaten, Baugrundrisse...

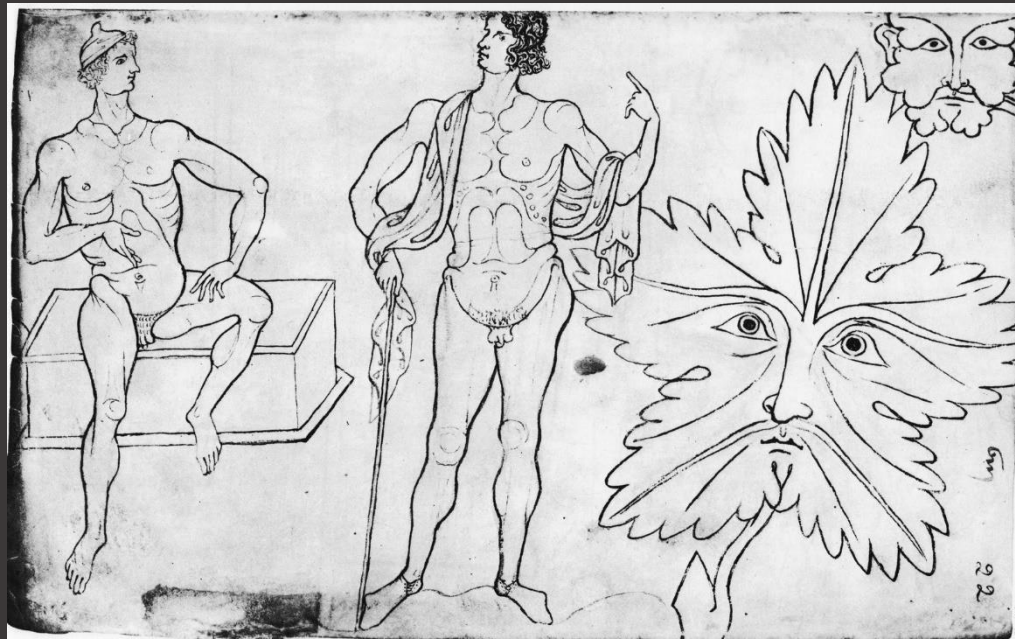
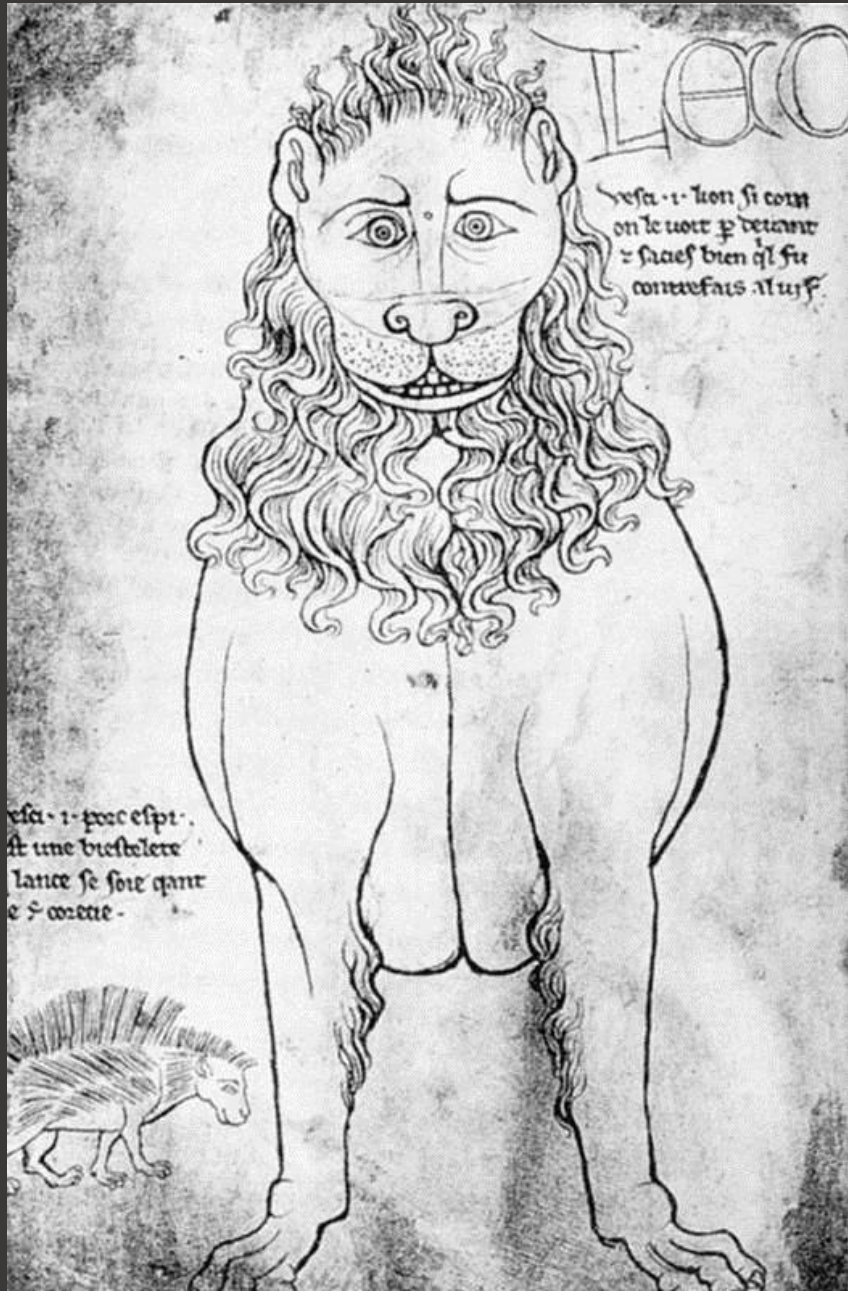

...Tiere, Skulpturen, Grotresken

<http://classes.bnf.fr/villard/feuillelet/index.htm>

Lausanne, Kathedrale

- Baubeginn Mitte 12. Jh, ersten Phasen über Fundamenthöhe jedoch erst um 1160-80
- Gotische Bauphase I mit Chorobergeschoss, Querhaus und Anfang des Langhauses Ende 12.Jh. fertig
- Gotische Bauphase II Rest des Langhauses und Westbau (lange Zeit bis zur Vollendung)
- Zahlreiche spätere Umbauten, im 19.und 20.Jh. tiefgreifende Restaurierungen (Schäden durch den sehr weichen Stein)

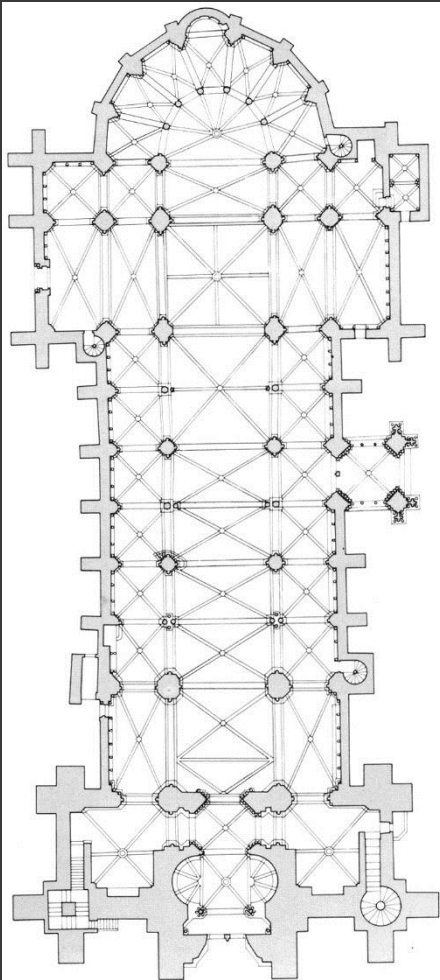

69 Campagne 2, état vers 1160
(avec le chevet de la cathédrale
romane situé à l'ouest).

70 Campagne 3, état vers 1175.

71 Campagne 4, état vers 1180.

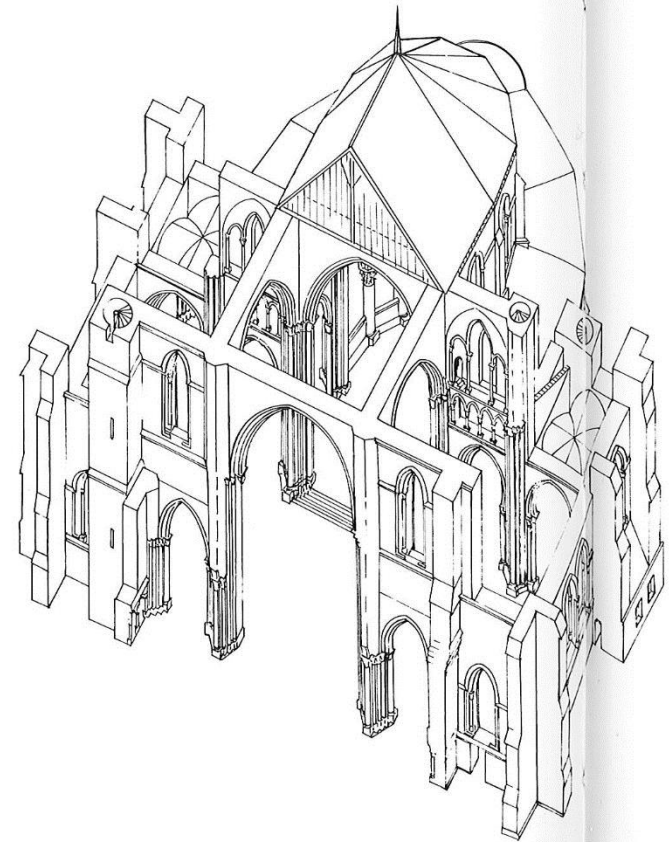
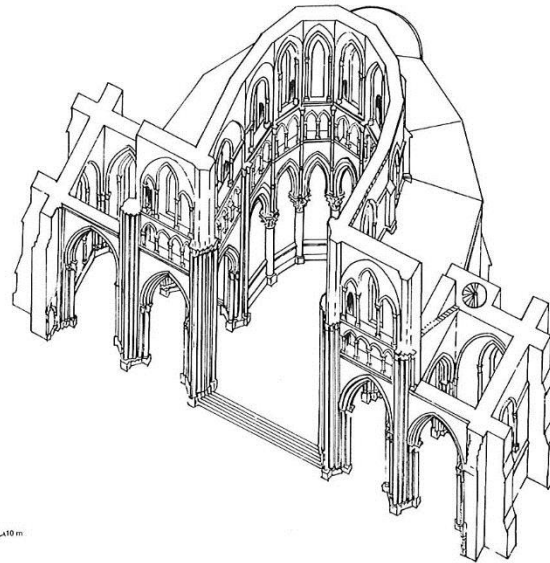
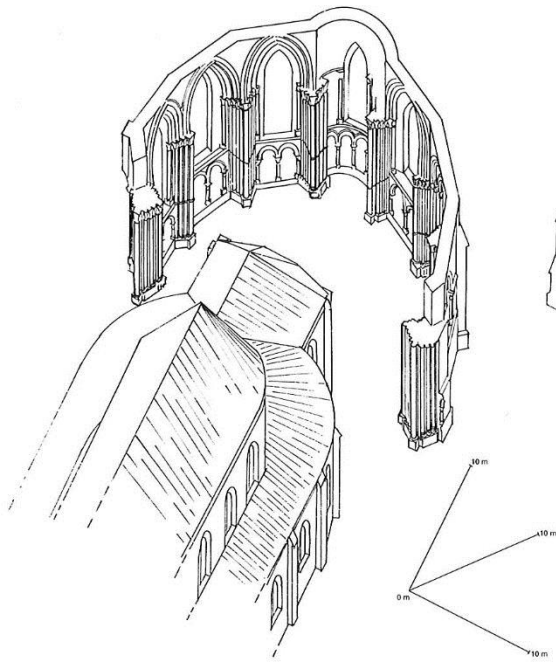

Isometrie/isometrische Darstellung der ersten Bauphasen: Baubeginn um den Vorgängerbau herum



Lausanne



Noyon



Lausanne



Laon



Lausanne

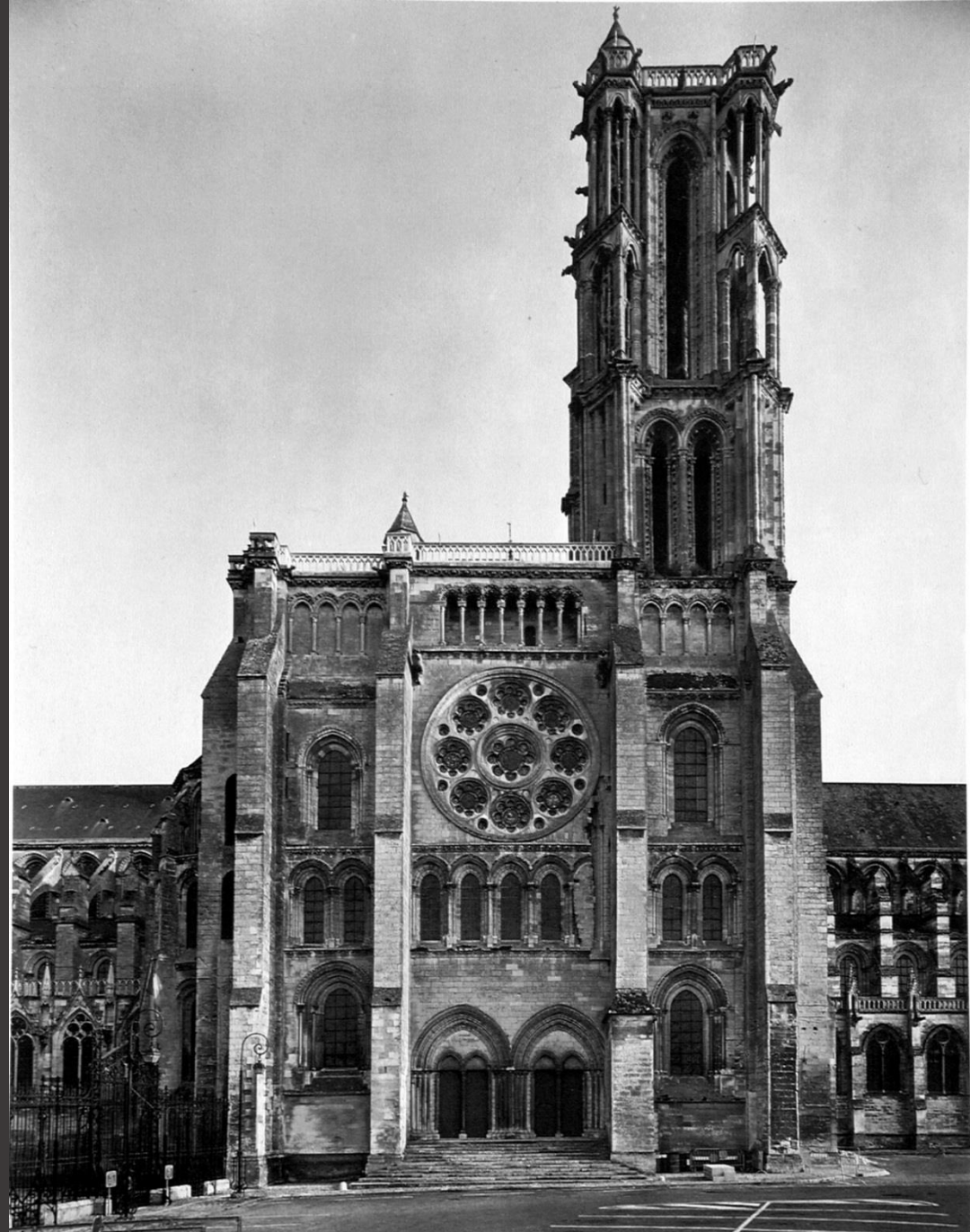

Laon

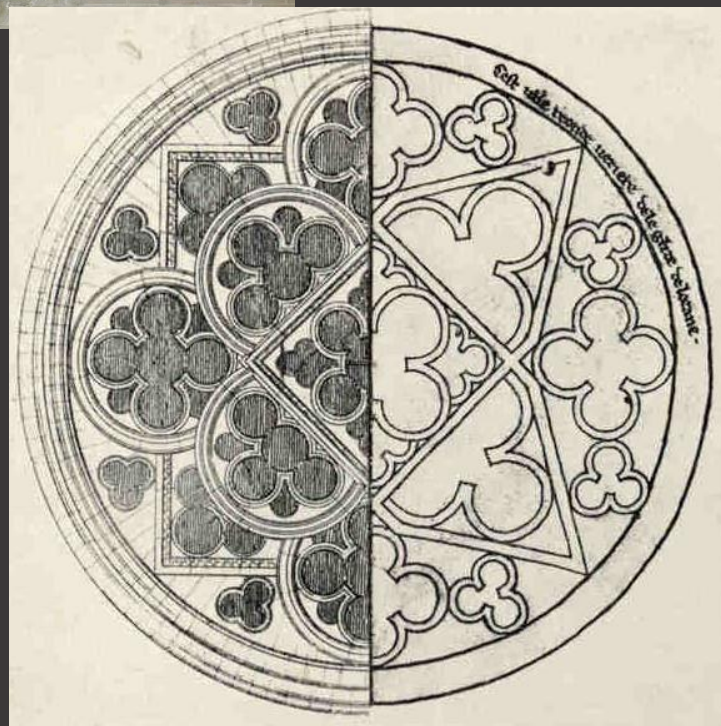
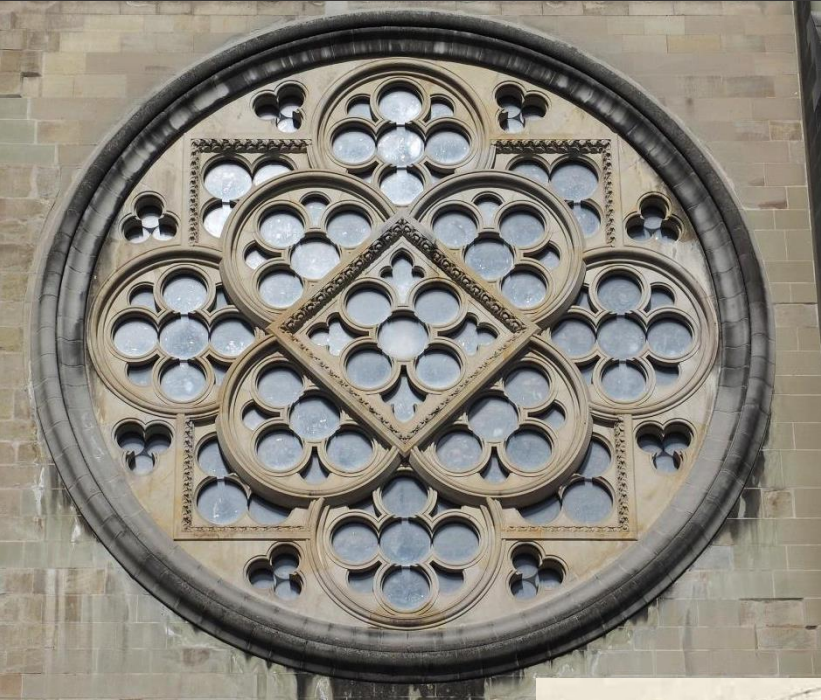

Skizzenbuch des Villard de Honnecourt

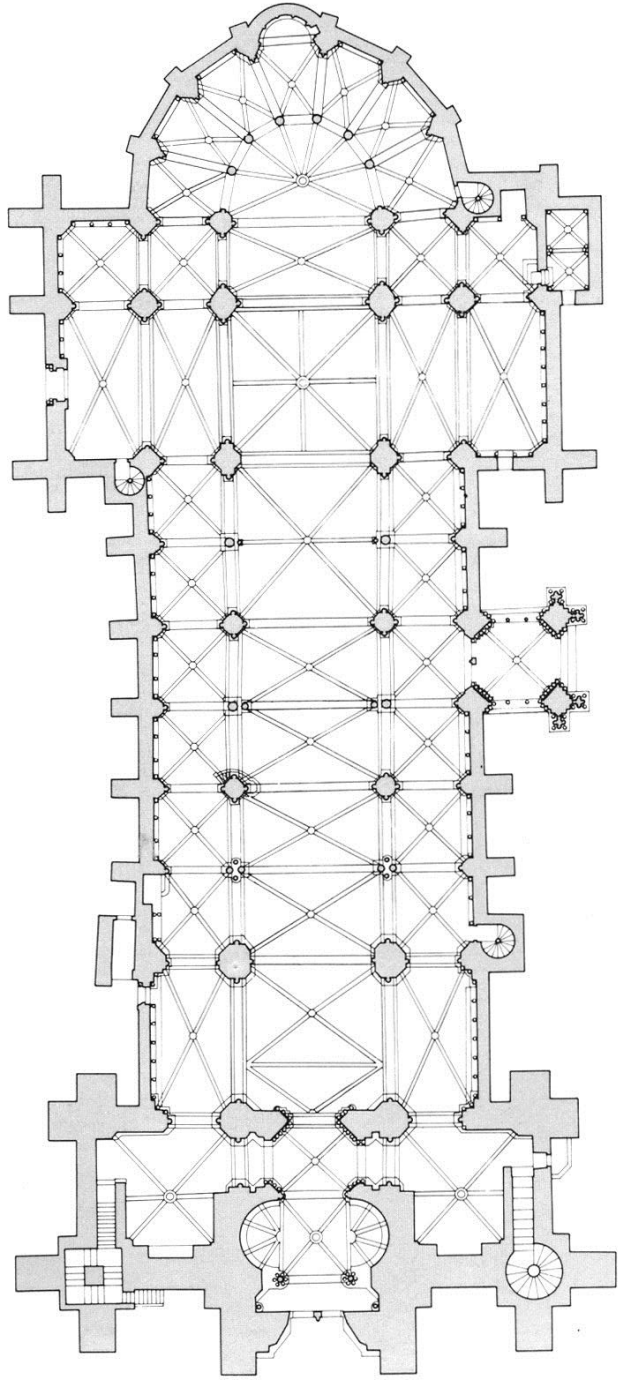

Lausanne
Cathédrale
première moitié du XIII^e siècle

0 5 10 15 20 m
Plan au 500*





Bündelpfeiler

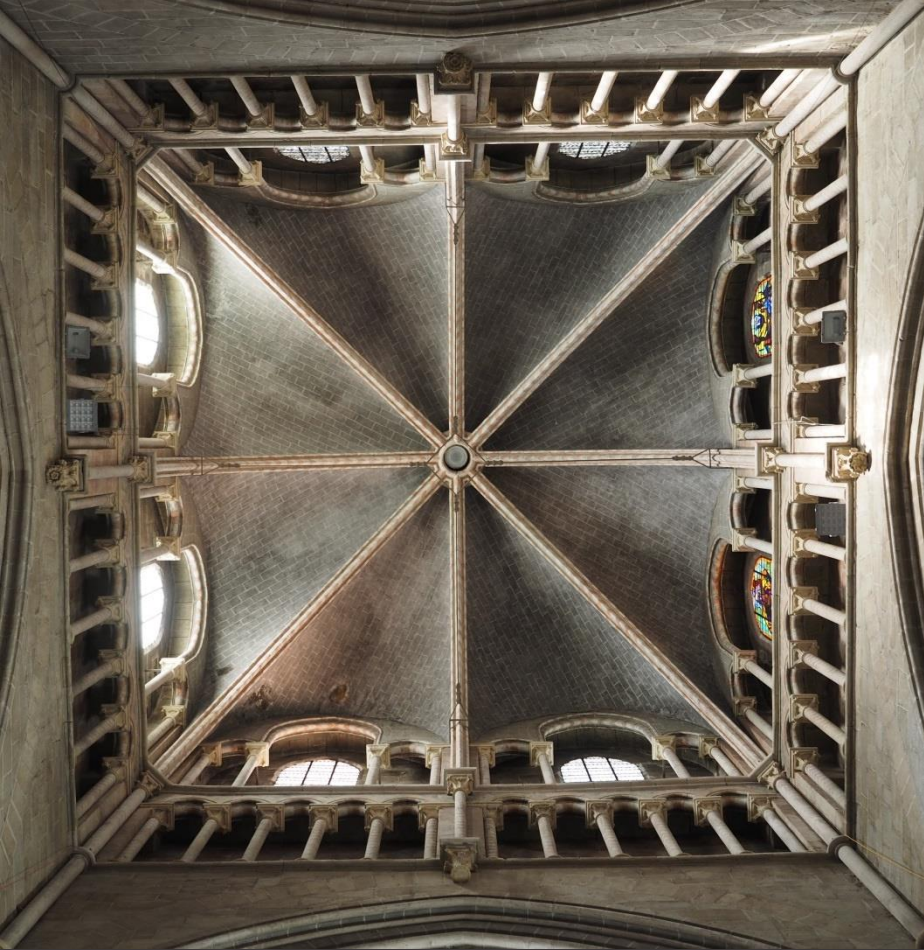

Lausanne

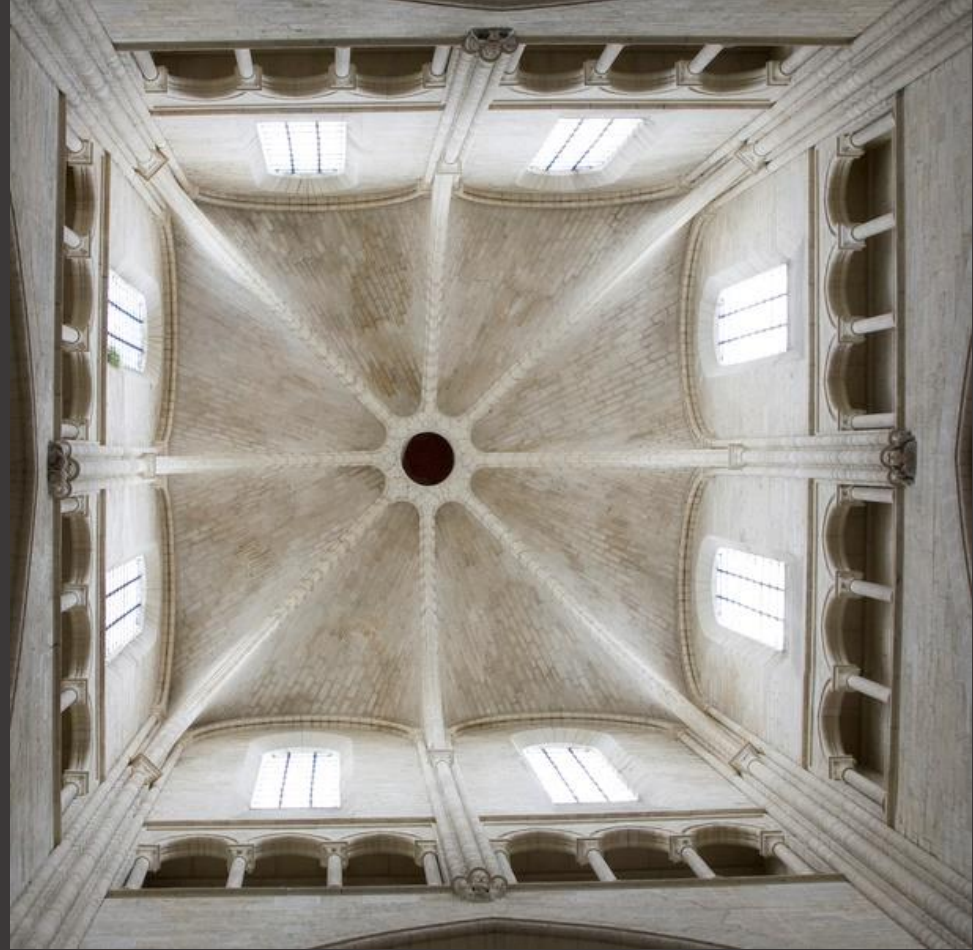

Laon



Lausanne, Querhaus
Um 1180



Noyon, Kathedrale, Querhaus
Um 1170



„en délit“-Dienst

In Richtung der geologischen Schichten aus dem Stein herausgearbeitet: nimmt nur geringe Lasten auf

Entwicklung der franz. Frühgotik

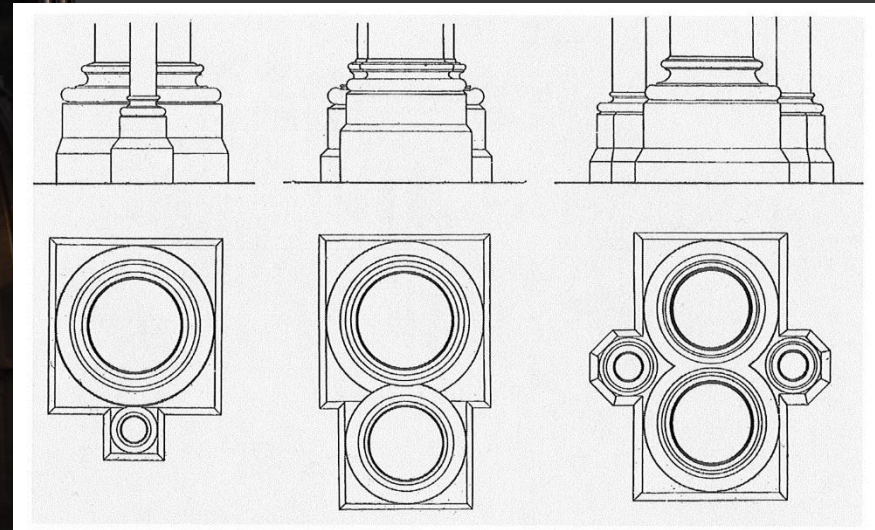



Lausanne



Laon

Kelchknospenkapitelle und
Zungenblattkapitelle



Notre-Dame, Paris

ab 1163 im spätromanischen Stil durch Bischof Maurice de Sully initiiert; ersetzt einen Bau des 6.Jhs.; königliche Hauskirche

1182 Chorweihe, langsamer Fortschritt bis 1220 (unterer Fassadenteil), 1250 Türme fertig; neues Dach in den 1220ern

schon ab 1230 Umbauten im neuen Rayonnant-Stil (Reaktion auf Kathedralen von Saint-Denis und Reims;

1250er-1270er Jahre neue Querhausfassaden mit monumentalen Fensterrosen

Chor bis ins 14. Jh. erneuert

18.Jh. Zerstörung der meisten Fenster und vieler Ausstattung, insbesondere 1793 (Revolution)

1831 Victor Hugo „Glöckner von Notre-Dame“

1844 Beginn der Restaurierung unter Eugène Viollet-le-Duc; insbesondere Dachreiter und obere Fassadenteile, Skulpturen



vor 1844

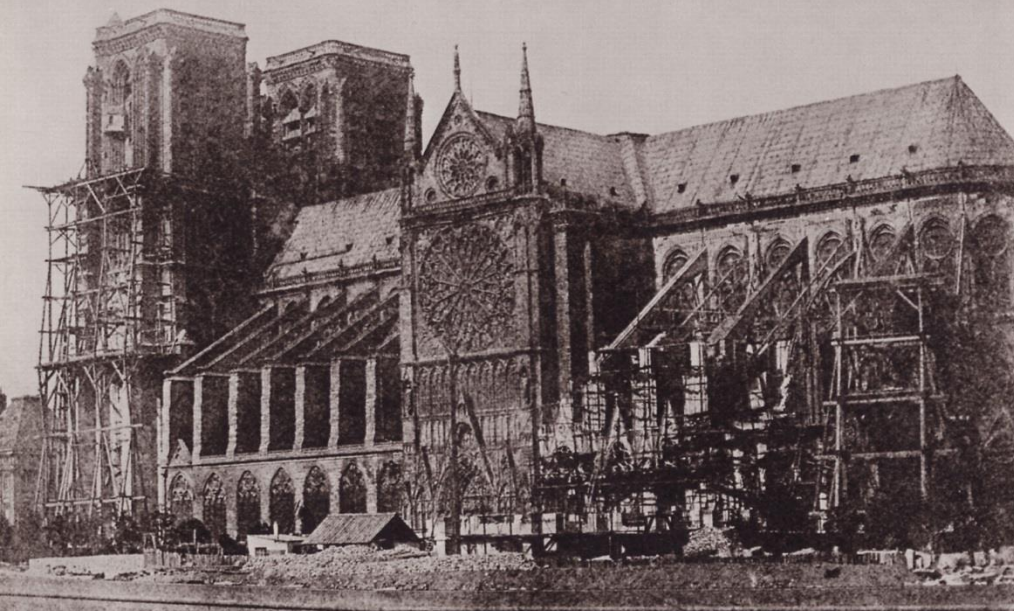

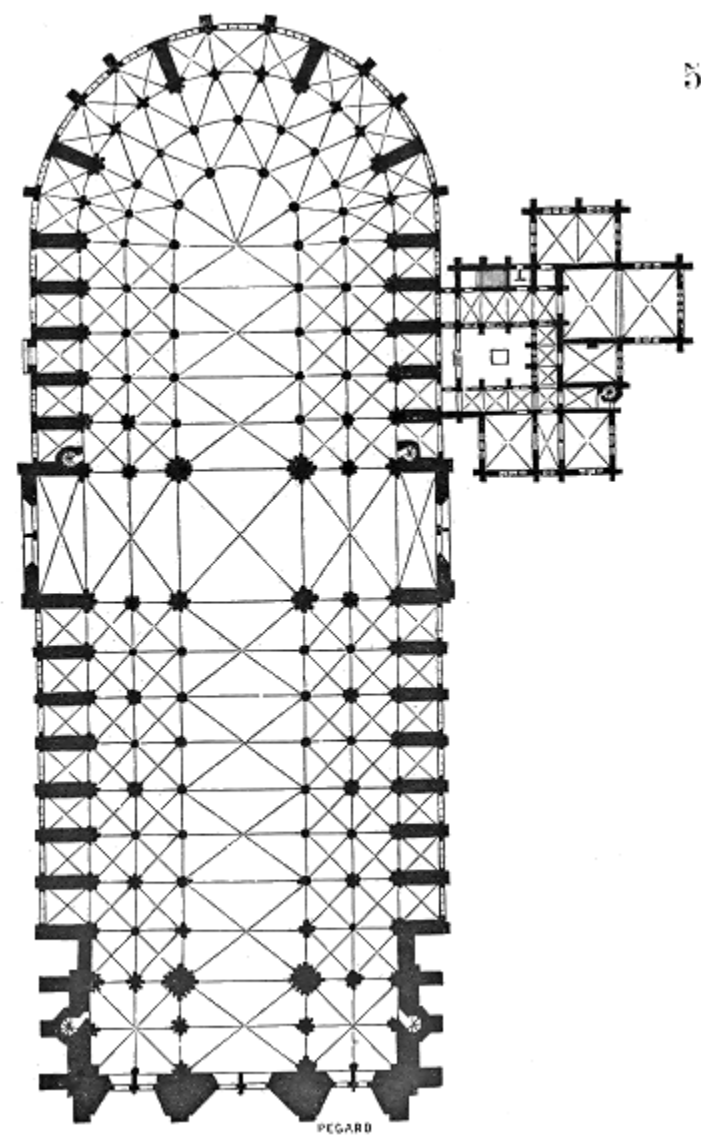

PEGARD

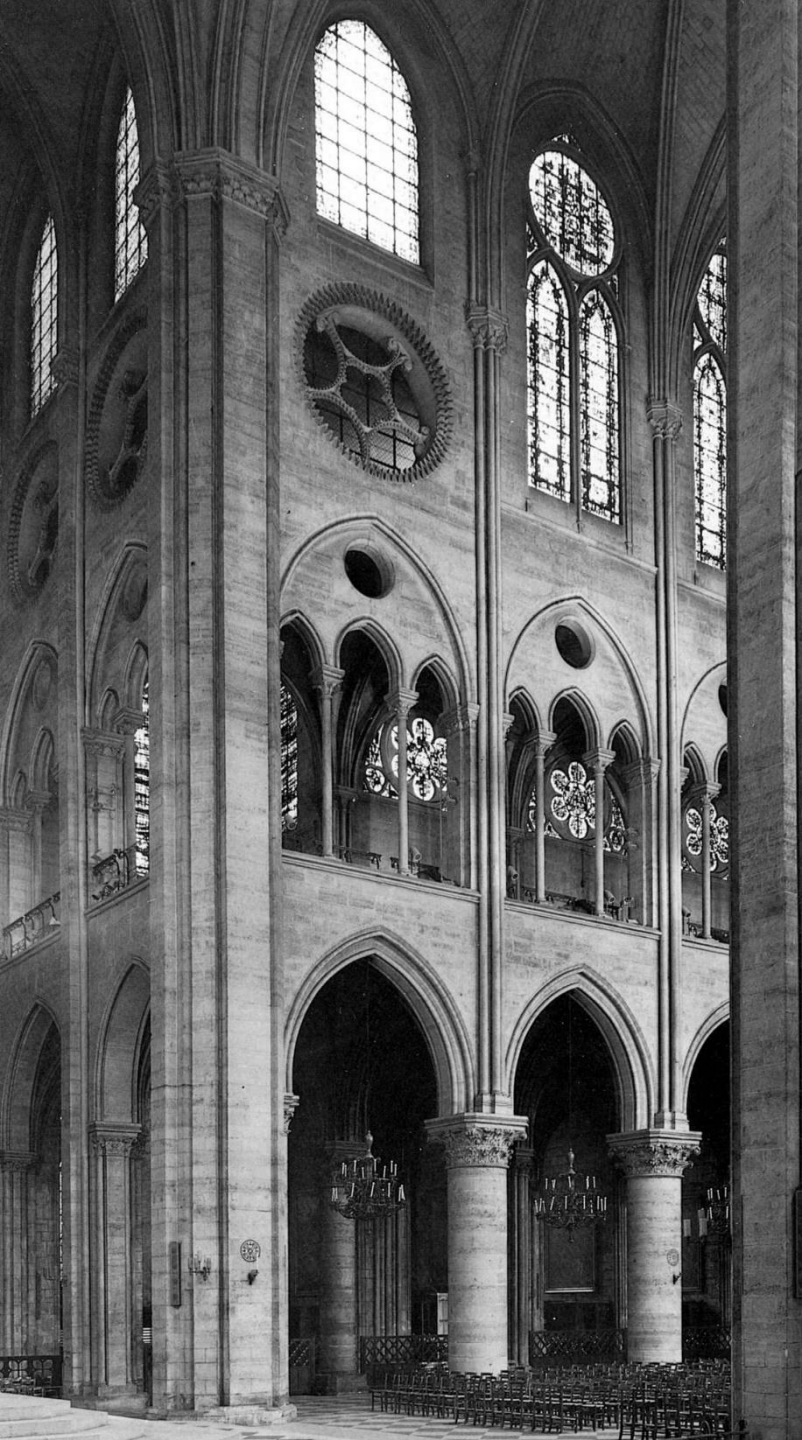

Vierung mit rekonstruierten Jochen des ursprünglichen Zustands, Langhaus nach dem Umbau der 1230er

Bau des 12. Jhs. noch ohne Masswerk

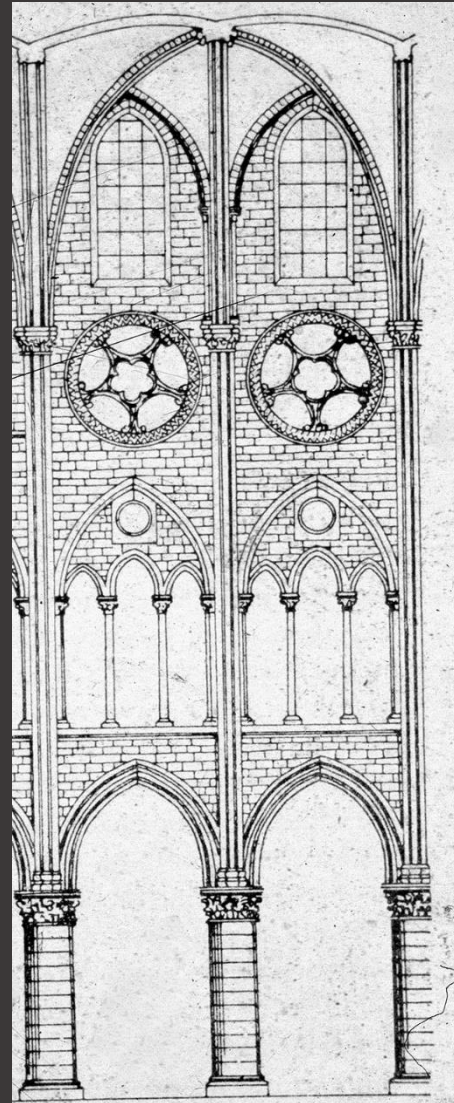



Paris, Notre-Dame



Laon



Paris, Fassade um 1200



Laon

Mantes-la-Jolie, Collégiale

Ca. 1170-1180

Enge Verwandtschaft mit
Ursprungsbau der Notre-
Dame



CHRONOLOGIE DE LA CONSTRUCTION

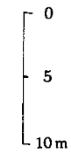

1170-1175

1175-1180

1^{re} moitié du
XIII^e

2^e moitié du
XIII^e

Limite occidentale
de la construction du
XII^e à l'étage des
tribunes

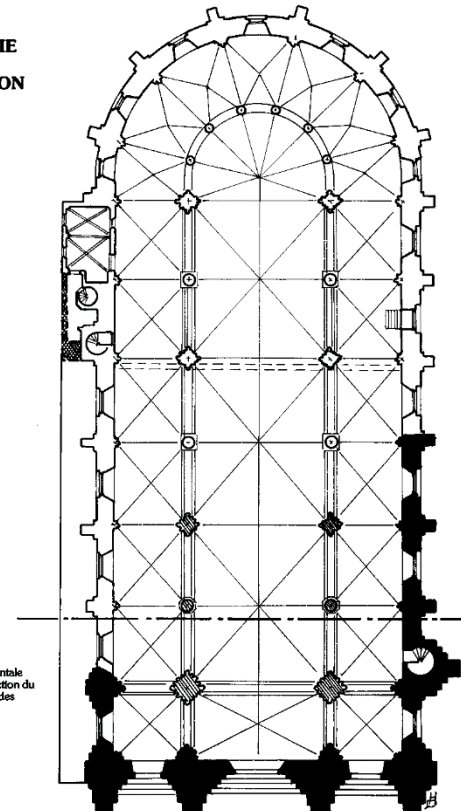



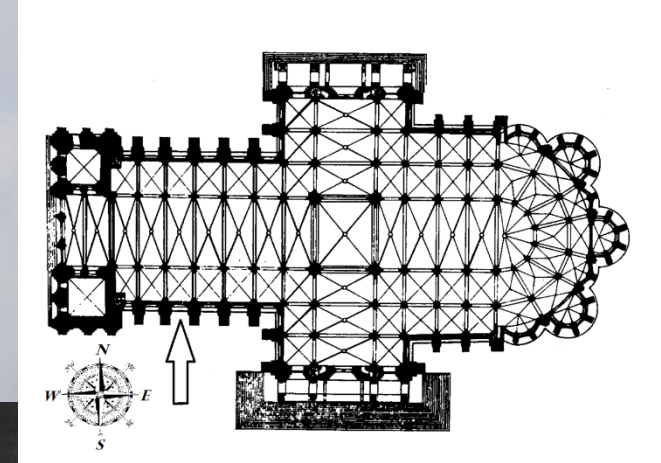

Chartres, Kathedrale

Ab 1194 nach Brand und Zerstörung der alten Kathedrale
und ihrer Marienreliquien



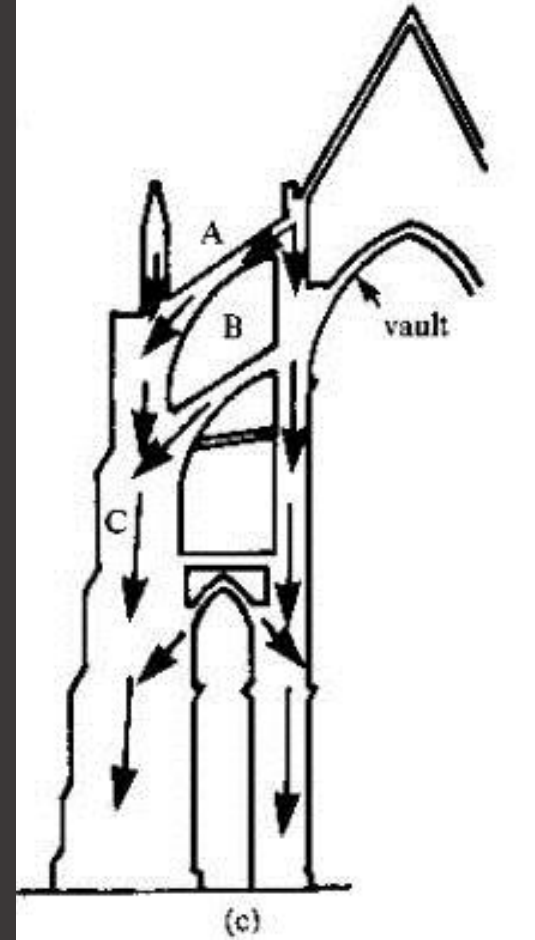
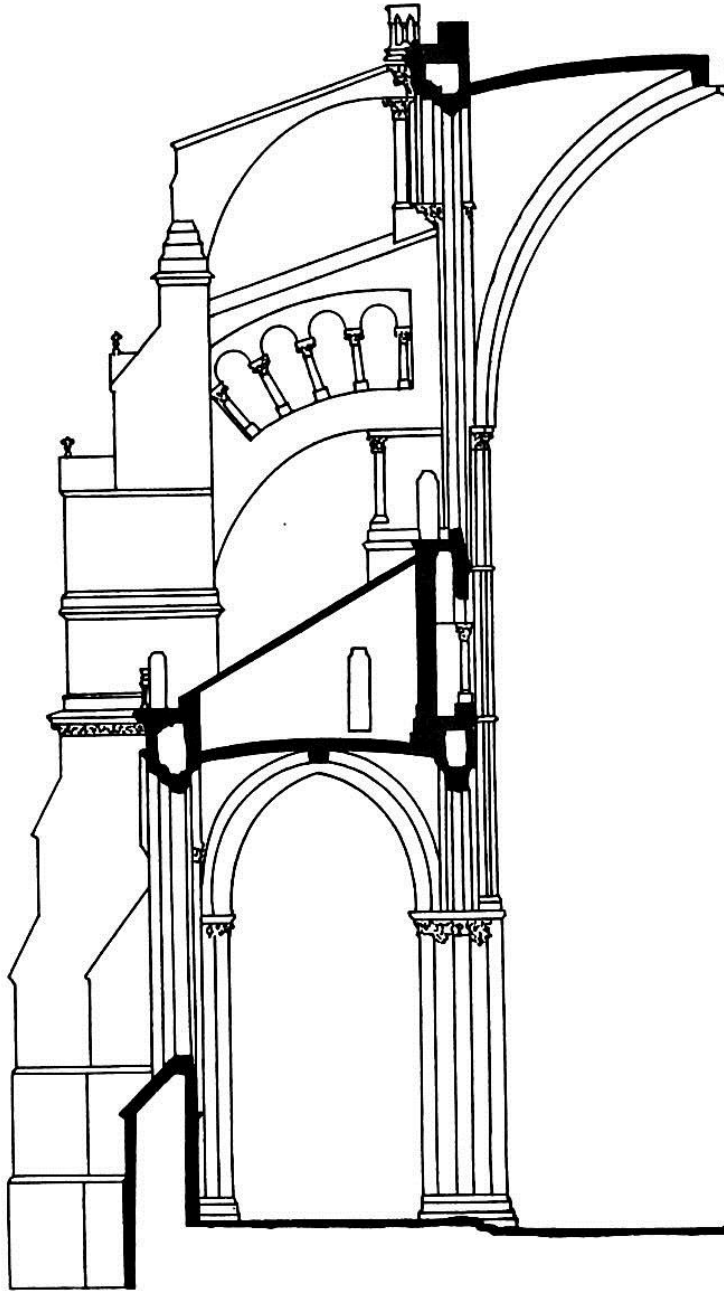

Strebewerk und Lastabtragung

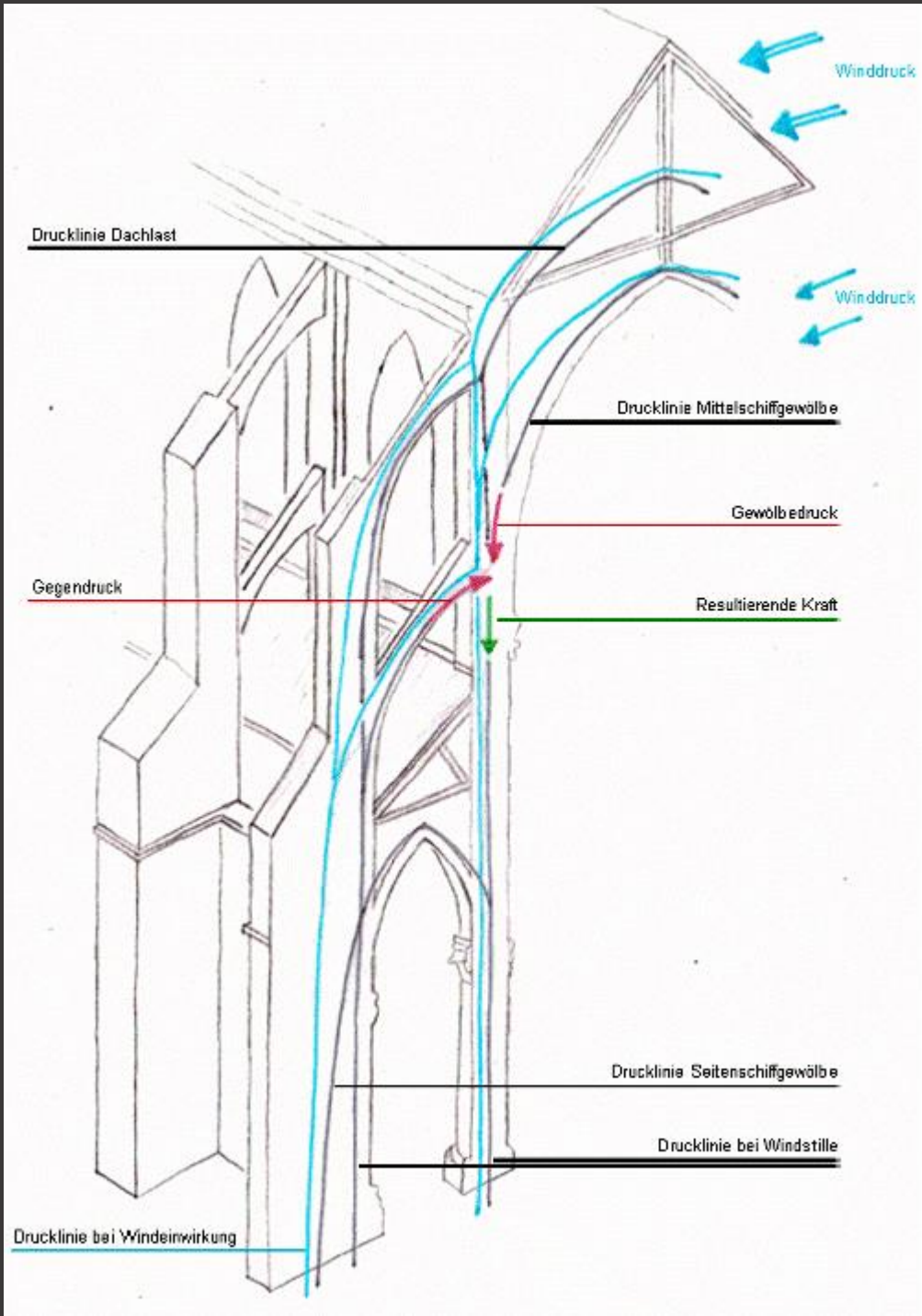

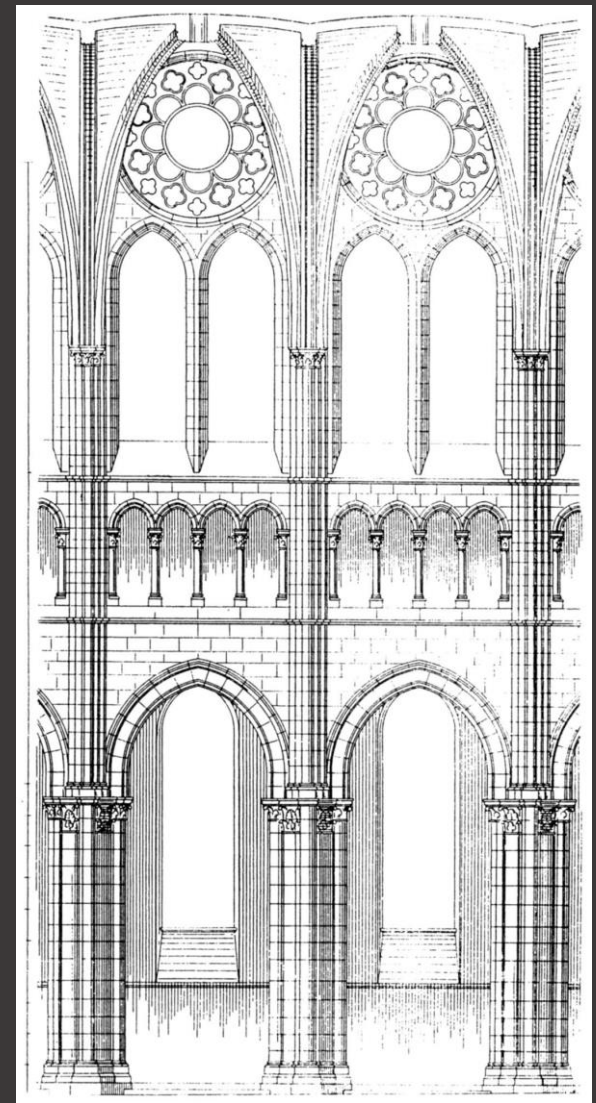

Dreigeschossiger Wandaufriß
Pfeilerkern mit Vorlagen umstellt

Plattenmaßwerk (Vorform echten
Maßwerkes)



Reims, Kathedrale
1210 Vorgängerbau niedergebrannt

königliche Krönungskathedrale:
monumentaler Neubau dringend
notwendig

1223 und 1226
Krönungszeremonien in offener
Baustelle

Fassade erst nach 1250,
Fertigstellung später im Jahrhundert



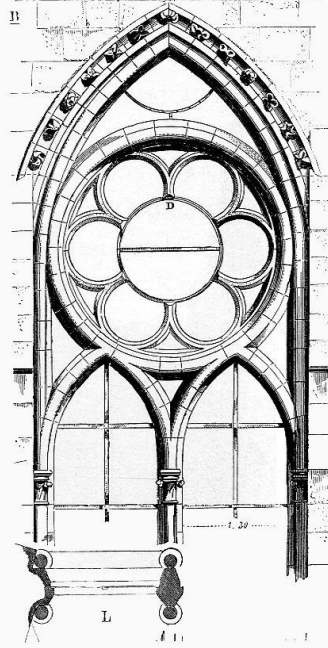
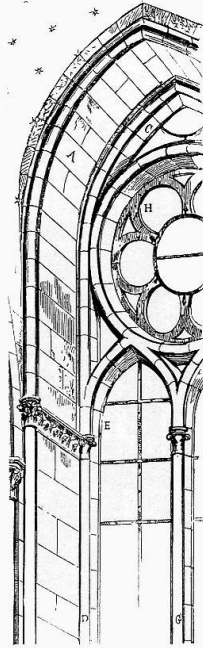
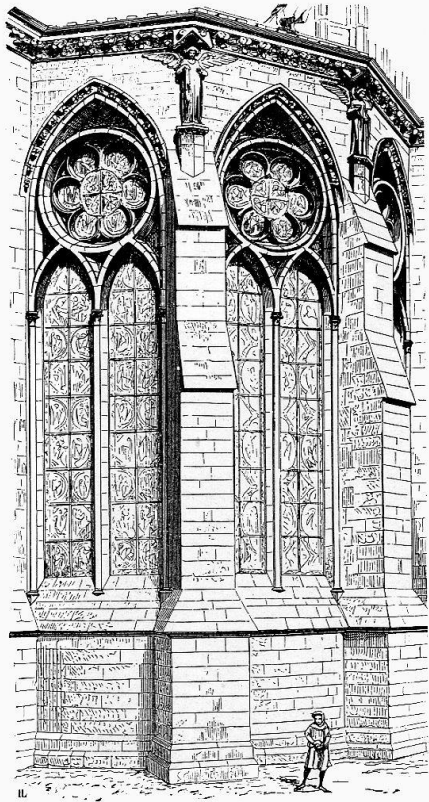

Maßwerk | *remplage (tracerie)*

Couronnement | *résau*
(mit Okulus/Rose | *avec oculus/rosace*)

Stabwerk mit zwei Lanzetten |
deux lancettes, un meneau

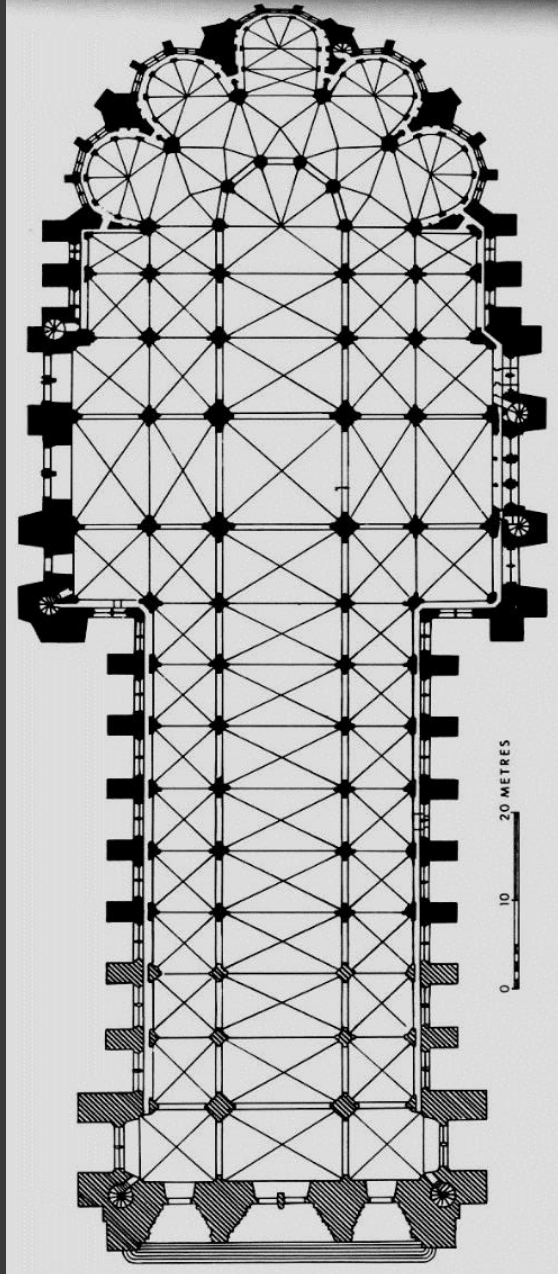

En trince bien a cet mouvent de nature le souuer de l'edifice sur leur raiement & de sur le omble de l'edifice et dore auec une de nature de nature
 a un tel d'edifice si comme nos. en le p'cedant de nature nos. & sur le mot de nos p'cedant d'ur autre angle & de nature au buter de nature le g'v
 a l'edifice de nature nos. & en le p'cedant de nature nos. & sur le mot de nos p'cedant d'ur autre angle & de nature au buter de nature le g'v
 a l'edifice de nature nos. & en le p'cedant de nature nos. & sur le mot de nos p'cedant d'ur autre angle & de nature au buter de nature le g'v

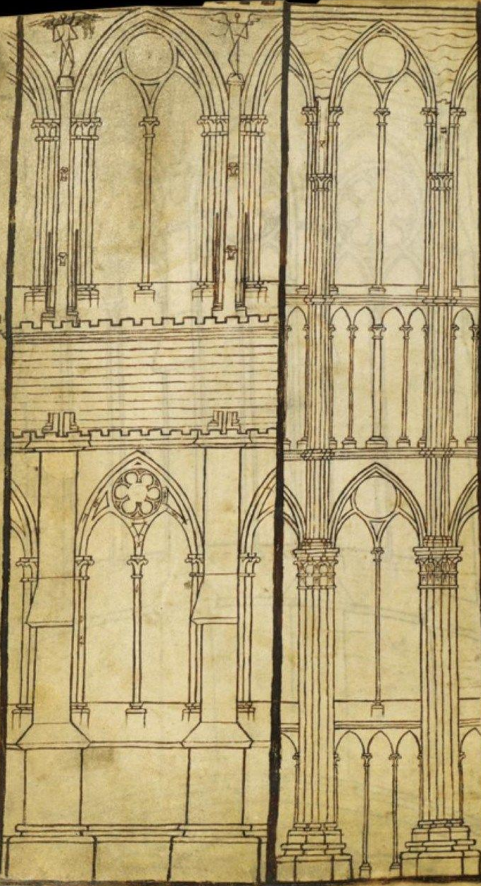

Si poel u uar lun des pieulz touant de le
 grez de rans. s. i. de ceul dentre. u. capieles.

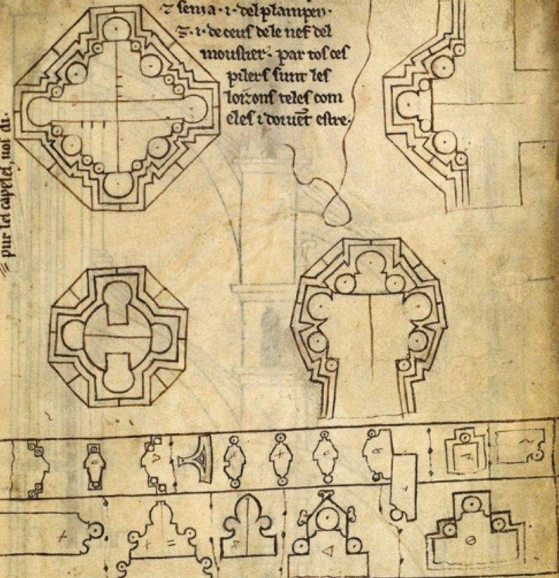

pur tel capiel, nos. de.

desu le molle des chapitel de cele p'agne la deuant. des formel. des
 uereres. des oguel. & des doubliaus. & des fouuol p' de seure.

desu les monteez de leglize de rans & del plain pen. dedent & de hors.
 Le premier estandement des acampes doit faire certain si q' p'uit
 auoir uoie deuant le couerue. encoutre ce uoite s'unt les uoies dedens.
 & pour cel uoies s'unt uoies. & en taileel. dont reuement les uoies de hors
 & pour aler deuant les faelz des uereres. en tailement daerai doit auoir
 certain con p'uit. aler deuant le couerue. des auec les manieres de cotes. de
 monteez.

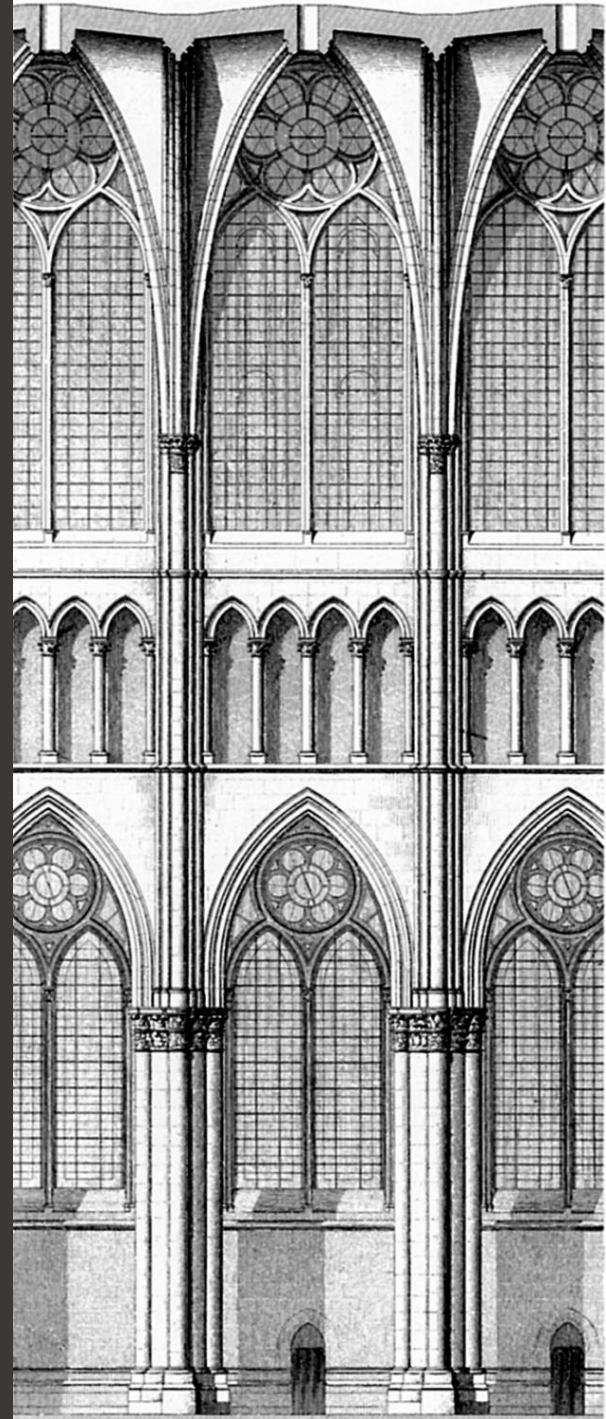



Chartres: Vorläufer



Reims: voll entwickelt

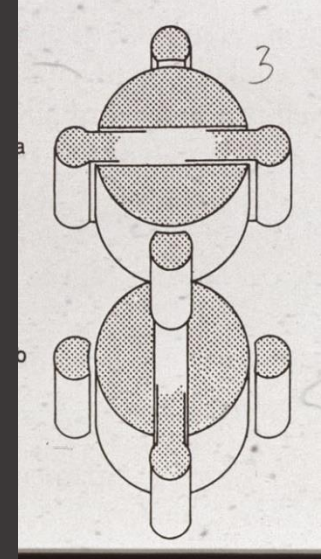
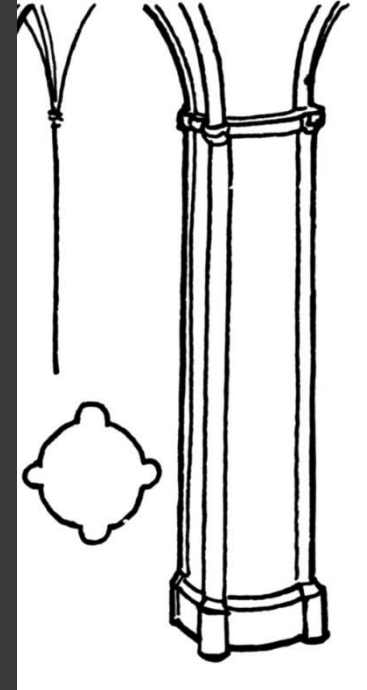

kantonierte Pfeiler | *pilier cantonné*



Chartres
Knospenkapitell | *chapiteau à crochets*



Reims
Blattkapitell | *chapiteau à feuillage*



Individuelle Kapitelle → Kapitellzone/Kapitellband

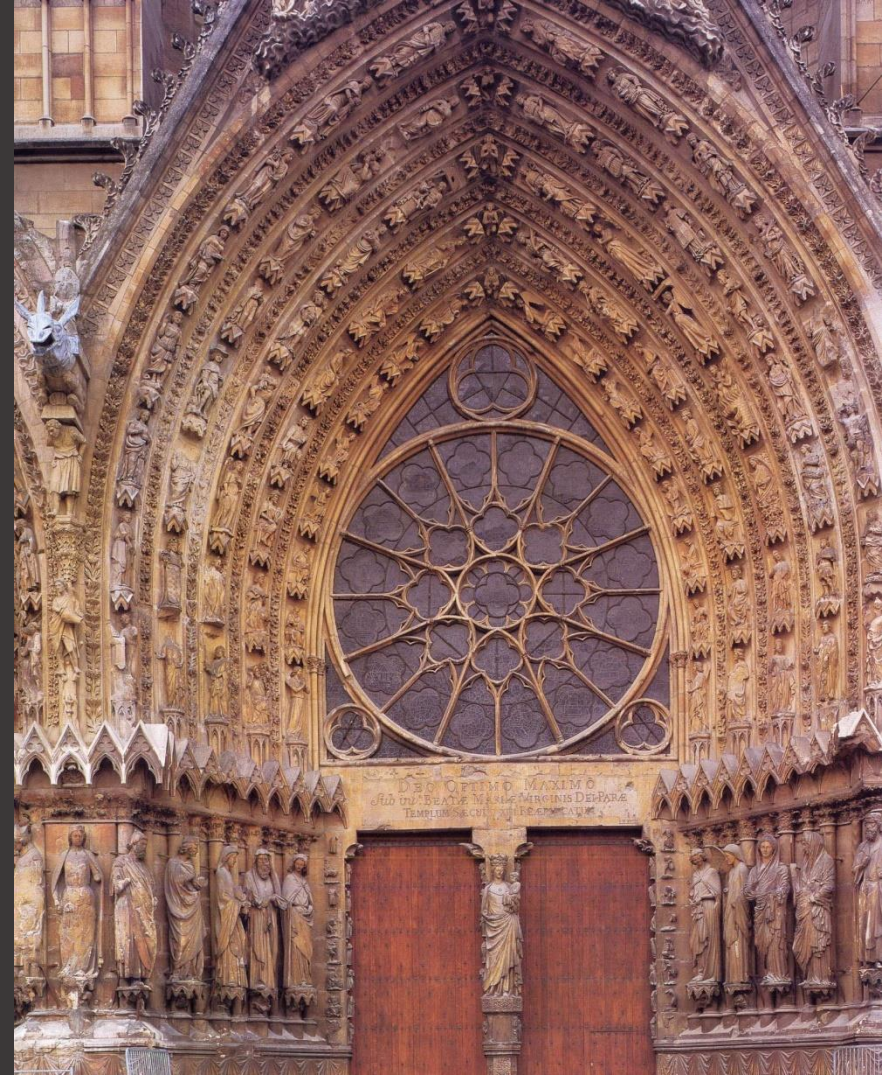



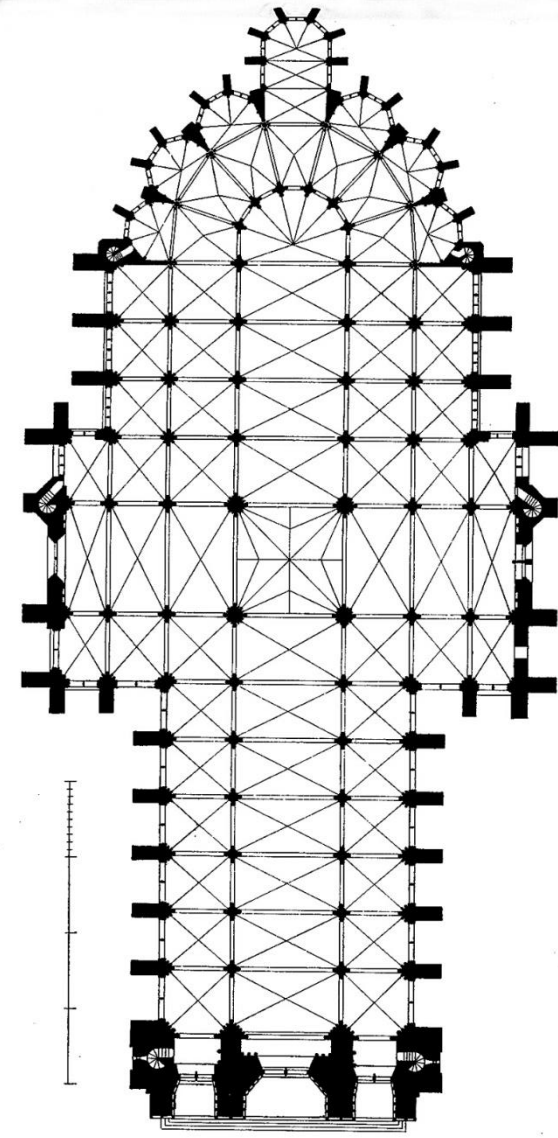

Amiens

1220-1288 Neubau nach Brand der alten, viel kleineren Kathedrale
Architekten: Robert de Luzarches, dann Thomas de Cormont, Renaud de Cormont

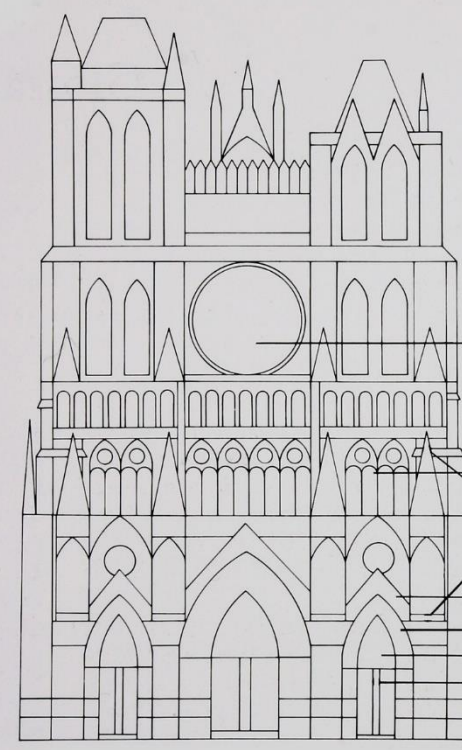
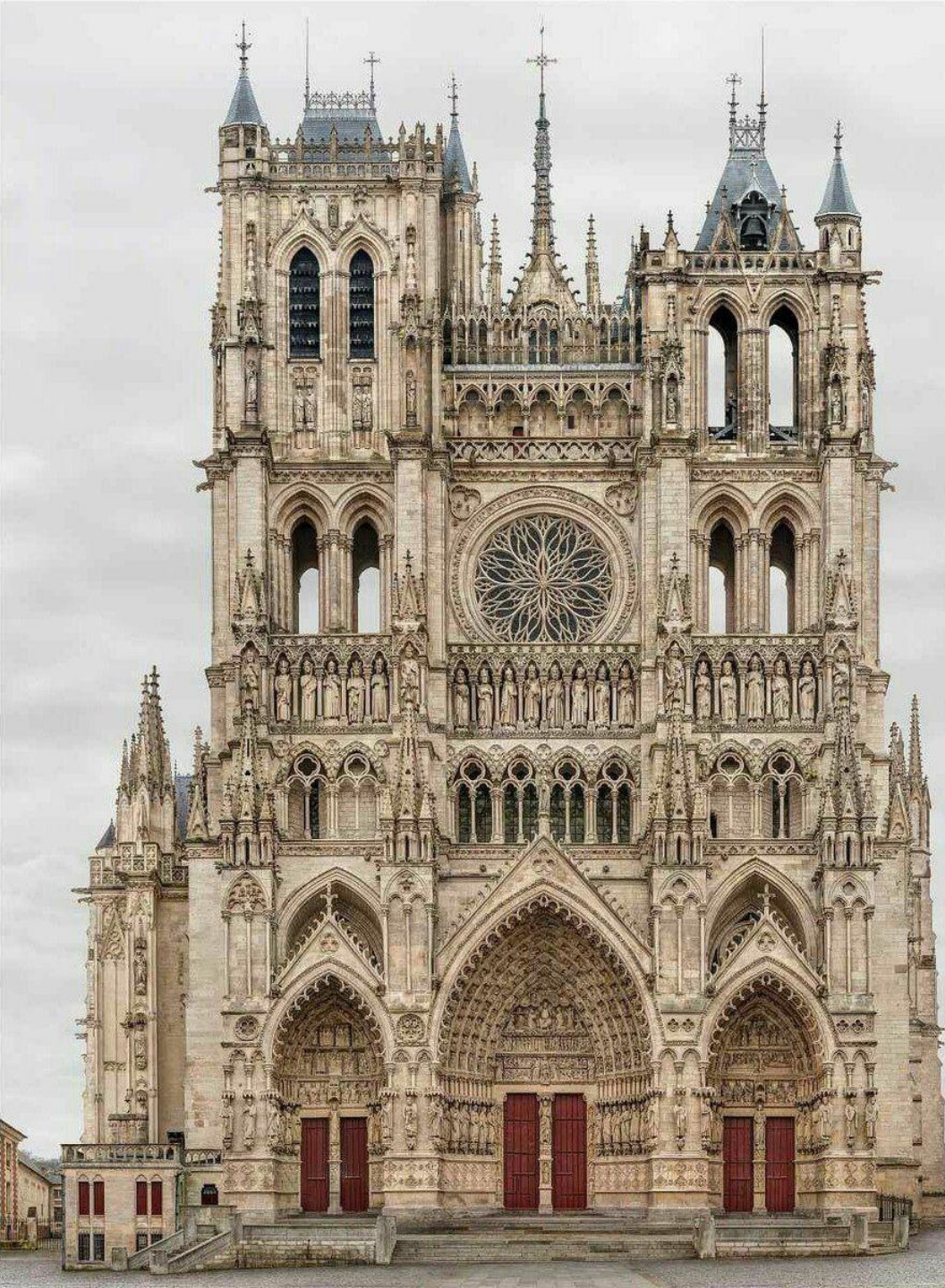

- Türme
- Freigeschoß mit Schallöffnungen für Glocken
- Rose
- Königsgalerie
- Galerie mit Laufgang
- Fiale
- Wimperg
- Archivolten (Bogenläufe)
- Tympanon (Bogenfeld)
- Trumeau (Türfeiler)
- Sockelstreifen mit Vierpaßreliefs
- Sockelstreifen mit Kreuzblumenornament



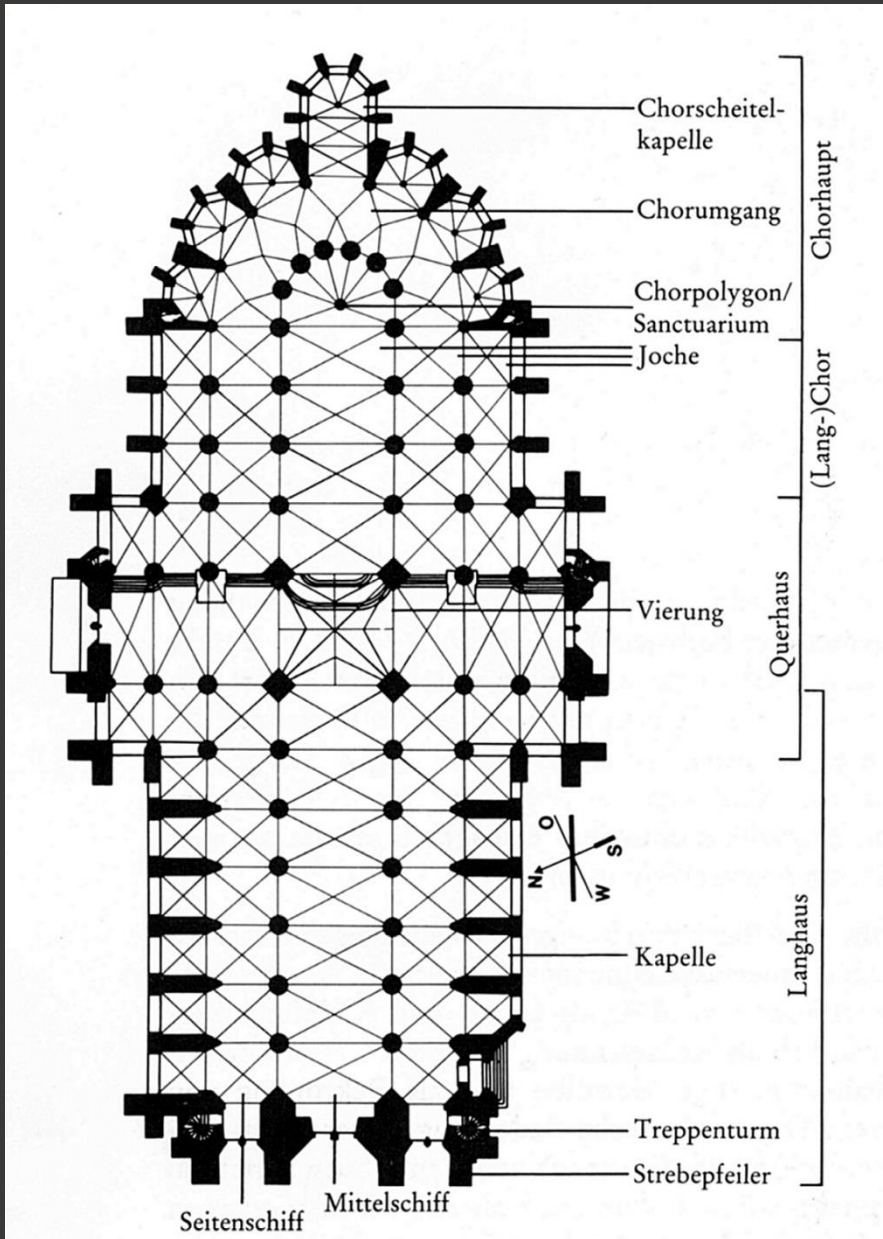
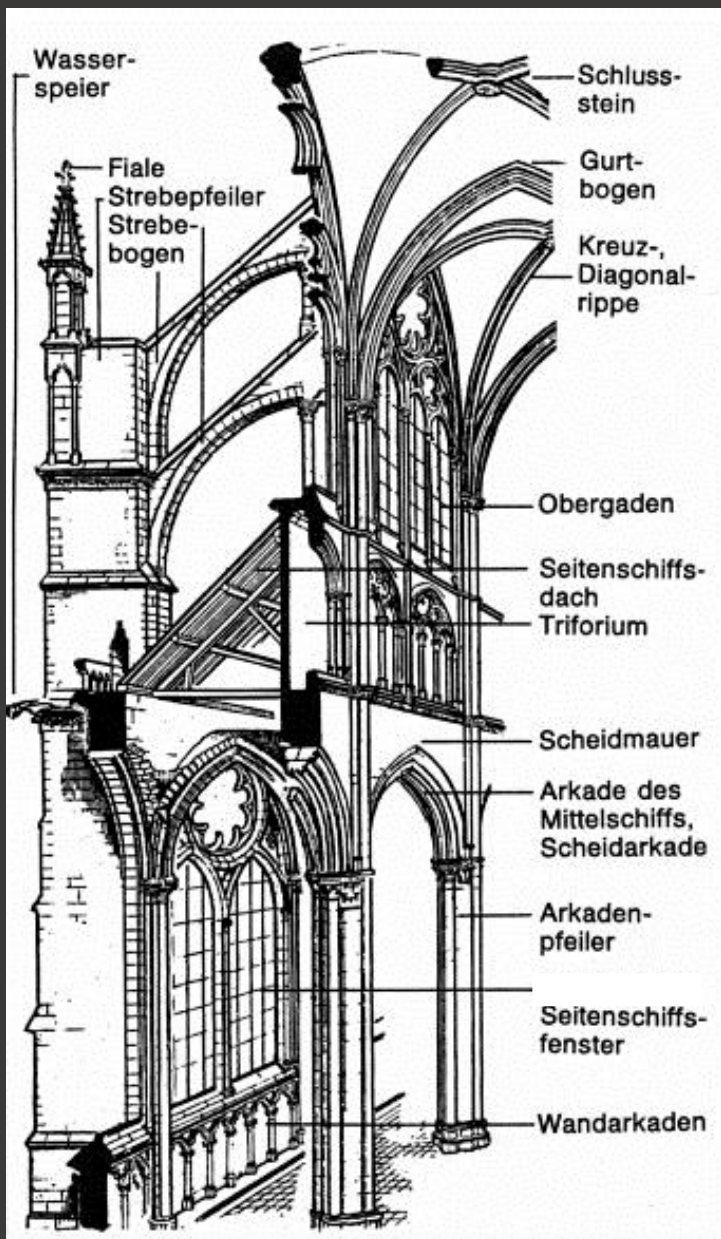





Amiens



Reims



Amiens: Triforium mit Masswerk, teilweise mit Fenstern
in der Rückwand



Amiens



Reims

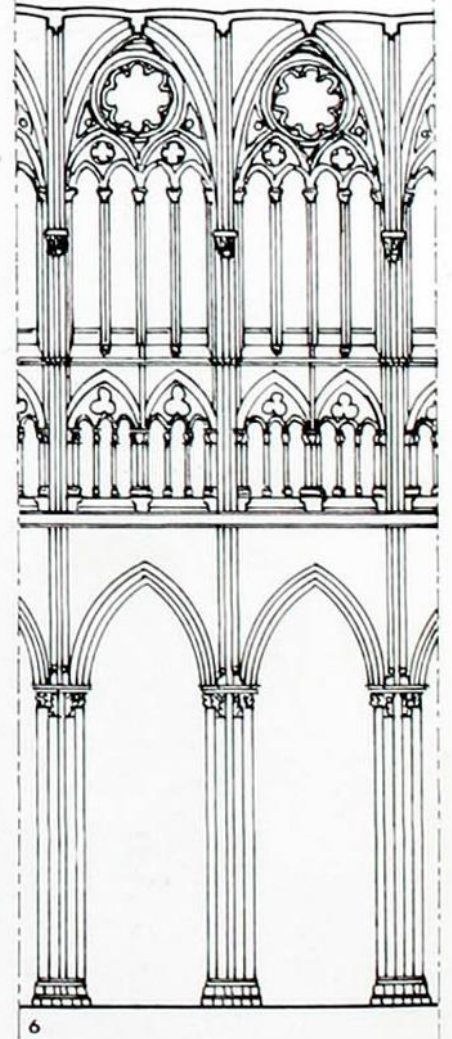
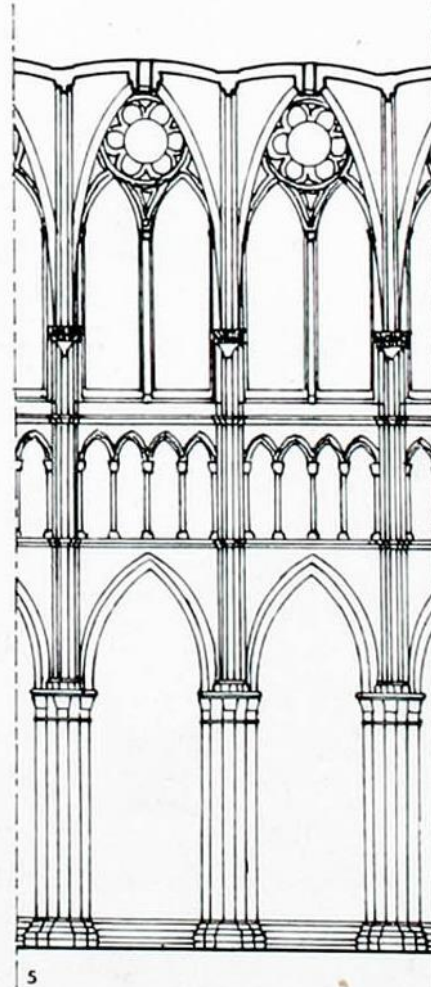
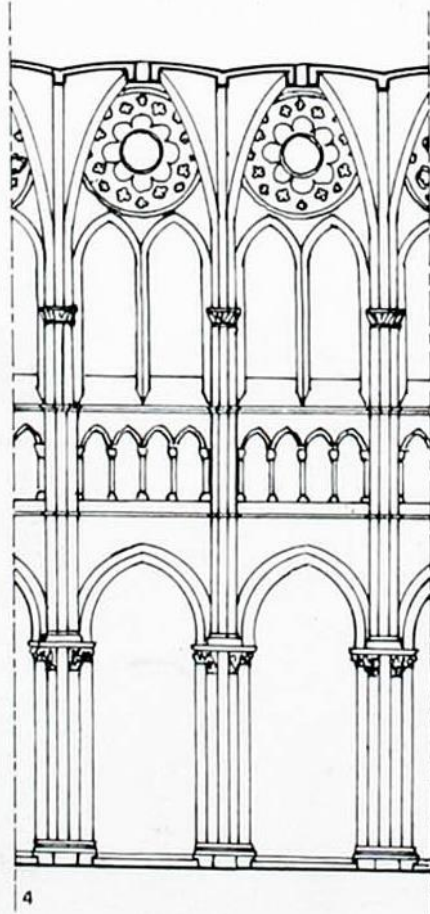
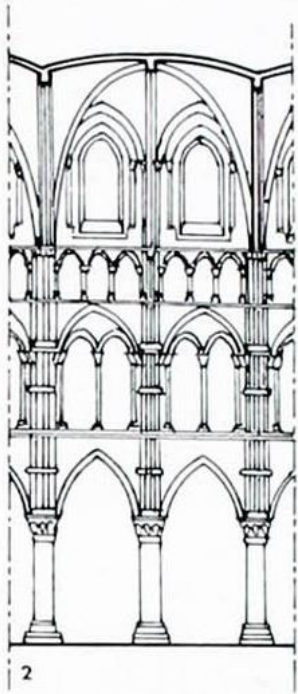

Laon

Chartres

Reims

Amiens